

LINEAR ACTUATOR

线性执行器 · 梯形螺杆

Product Manual · 产品手册

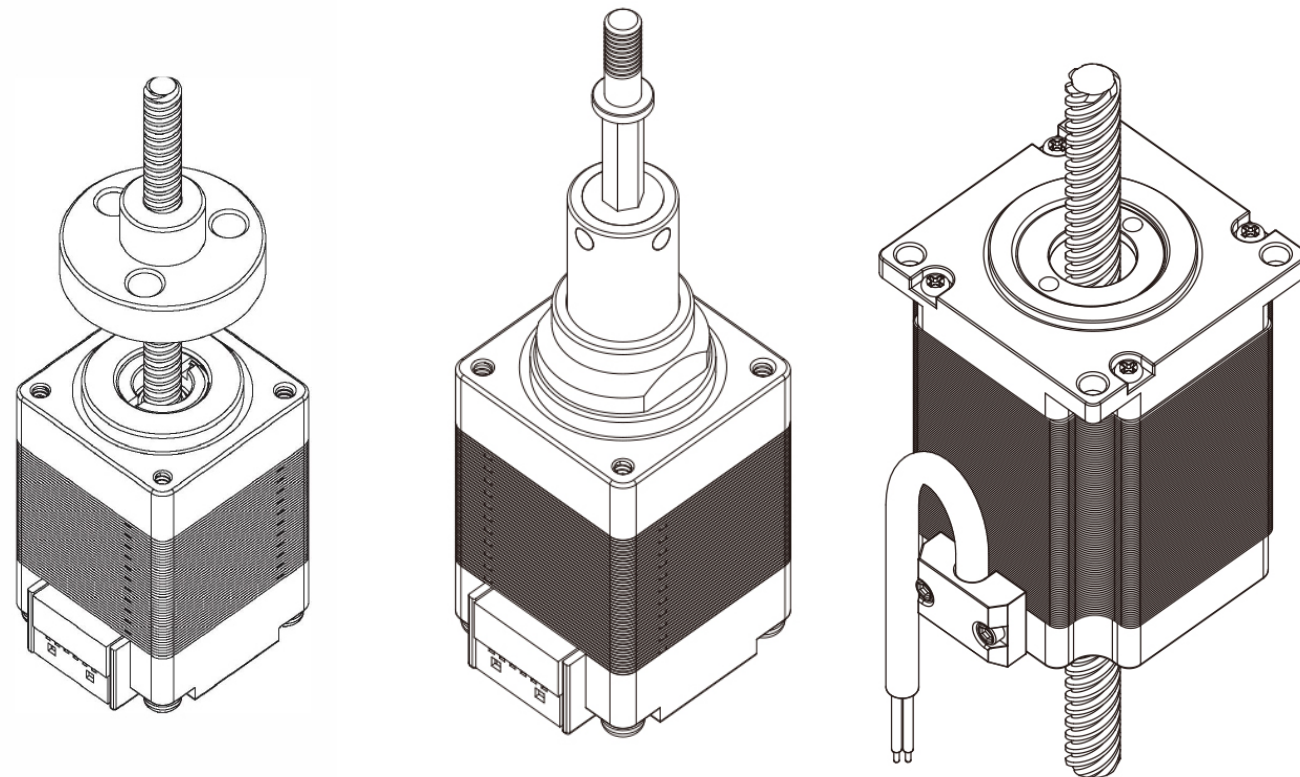

20系列T形外驱式电机-8HY

External Linear Actuator With T-Screw – NEMA 8

灵活的紧凑型直线步进电机，尺寸为 NEMA 8 (20 mm)，定位时间短、推力和拉力大。带有梯形螺纹。提供多种长度和不同的绕组。

Flexible and compact linear stepper motor, size NEMA 8 (20 mm), short positioning time, high thrust and pull. The threaded nut is injection molded into the hollow shaft with a trapezoidal thread. Provide multiple lengths and different windings.

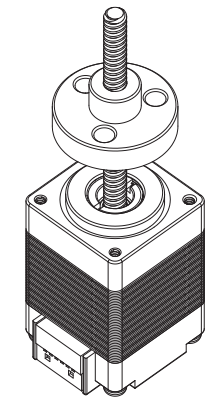

◎ Feature

- External Linear linear actuator 外驱式线性执行器
- 20mm small size 20系列法兰
- Encoder optional 可配套编码器
- Longer life and higher accuracy 更长的寿命和更高的精度
- Different lengths available 提供不同长度
- Motor Controllers / Drives available 电机控制器/驱动器可用

◎ VERSIONS

系列代码 Series models	8HY30	8HY40
相电流 Current per Winding A	0.6	0.6
静力矩 Holding Torque mN.m	18	32
相电阻 Resistance per Winding Ohm	6.5	6
相电感 Inductance per Winding mH	1.7	2
转子惯量 Rotor Inertia gcm ²	2	3
电机重量 Weight kg	0.06	0.1
电机高度 Length "L" mm	30	40
螺杆长度 Screw length*L1	Different lengths available	Different lengths available
反馈装置 Feedback	Encoder(Closed-loop version)	Encoder(Closed-loop version)

订货代号 ORDER IDENTIFIER

8HY20T35061-E2000-L1
 T35061=T-Screw code
 丝杠代码
 L1 = Screw length
 丝杠长度
 E2000=Encoder 2000/Resolution
 E2000=编码器 2000刻度

可选螺杆 Screw optional

Screw	Diameter	Screw (mm)	Step(mm)
T35-0.61	3.5	0.61	0.003048
T35-1	3.5	1	0.005
T35-1.22	3.5	1.2192	0.006096
T35-2.44	3.5	2.4384	0.012192
T35-4	3.5	4	0.02
T5-8	5	8	0.04

可选配件 ACCESSORIES

Motor Controllers / Drives
 电机驱动与控制器
 Standard nut 标准螺母
 Clearance nut 消间隙螺母

DIMENSIONS (IN MM)

