

SPECIFICATION	CONNECTION	DELTA
NO. OF POL./PHASE		8/3
VOLTAGE RATED (VDC)		48
CURRENT RATED/PEAK (AMP)		6.25/17.95
TERMIANAL RESISTANCE/PHASE-PHASE(Ohms) @25°C		0.34±15% \triangle
TERMIANAL INDUCTANCE/PHASE-PHASE (mH) @1KHz		1±20% \triangle
TORQUE RATED/PEAK (Nm) [lb-in]		0.70/2.01 [6.2/17.79]
TORQUE CONSTANT (Nm/A) [lb-in/A]		0.112[0.99]
POWER RATED (W)		250
SPEED RATED/NO LOAD (RPM)		3000/4500
ROTOR INERTIA (Kg-m ²) [lb-in ²]		8.0x10 ⁻⁵ [0.273]
WEIGHT (Kg) [lb]		1.85 [4.08]
TEMPERATURE RISE: MAX.80°C		
AMBIENT TEMPERATURE -10°~ 50°C [14°F ~ 122°F]		
INSULATION RESISTANCE 100 MOhm (UNDER NORMAL TEMPERATURE AND HUMIDITY)		
INSULATION CLASS B 130° [266°F]		
DIELECTRIC STRENGTH 500VAC FOR 1 MIN. (BETWEEN THE MOTOR COILS AND THE MOTOR CASE)		
AMBIENT HUMIDITY MAX. 85% (NO CONDENSATION)		

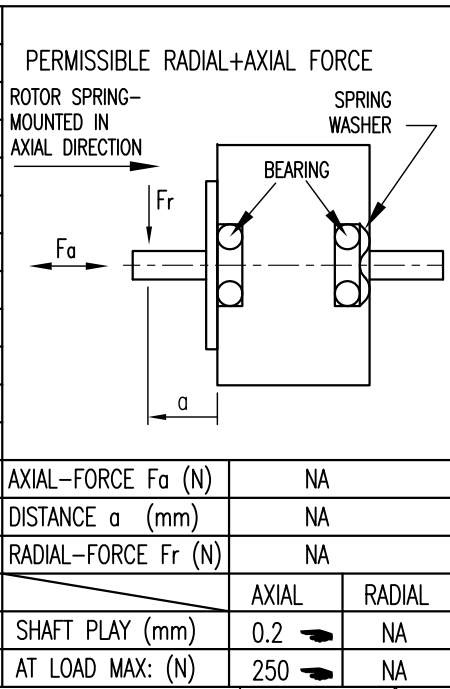

TWINTUS CONNECTOR M12 12 POLE	
PIN NO.	ENC./HALL
1	GND
2	5 V
3	GND
4	A
5	A\
6	B
7	B\
8	I
9	I\
10	H1
11	H2
12	H3

TWINTUS CONNECTOR M16 6 POLE \triangle	
PIN NO.	FUNCTION
1	U
2	U
3	V
4	V
5	W
6	W
PE	PE

WIRING DIAGRAM \triangle						
FUNCTION	ROTATION: CW VIEWED FROM THE OUTPUT SHAFT \triangle					
	HI	HI	X	LOW	LOW	X
U	HI	HI	X	LOW	LOW	X
V	LOW	X	HI	HI	X	LOW
W	X	LOW	LOW	X	HI	HI
+5V						
H1	0	0	0	1	1	1
H2	1	1	0	0	0	1
H3	0	1	1	1	0	0
GND						

\rightarrow : Axial play is below 0.2mm at 250N force.

03	FLANGE THICKNESS	25.07.16	GYQ
02	M16 CONNECTOR WITH 6 POLE	26.10.12	J.W.
01	RESISTANCE+INDUCTANCE+ROTATION...	04.05.12	GYQ
REV	DESCRIPTION	DATE	DRN

Nanotec
PLUG & DRIVE
ASB87S048030-ENM

SCALE	FREE	APVD	J.W.	02.01.12
X	±0.5	CHKD	L B	25.07.16
1PL	±0.2	DRN	GYQ	02.01.12
2PL	±0.1	SIGNATURE		DATE
ANGLE	±30°			

DC MOTOR IN PROTECTION
DWG.NO ASB87S048030-ENM