

贯通轴式滚珠直线步进电机-57MBTG

Through-shaft Linear Actuator With Ball Screw – NEMA 23

DIMENSIONS (IN MM)

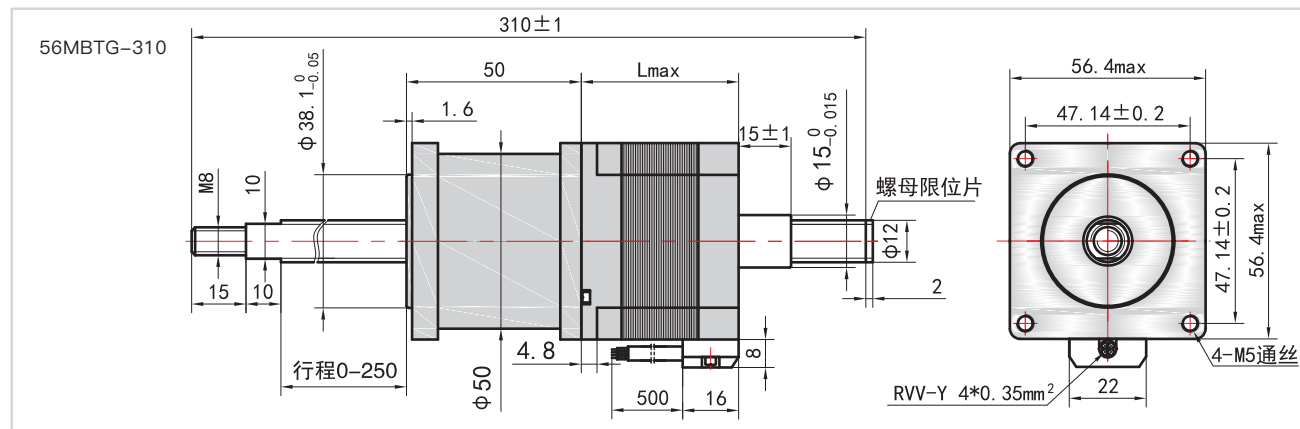

DIMENSIONS WITH ENCODER (IN MM)

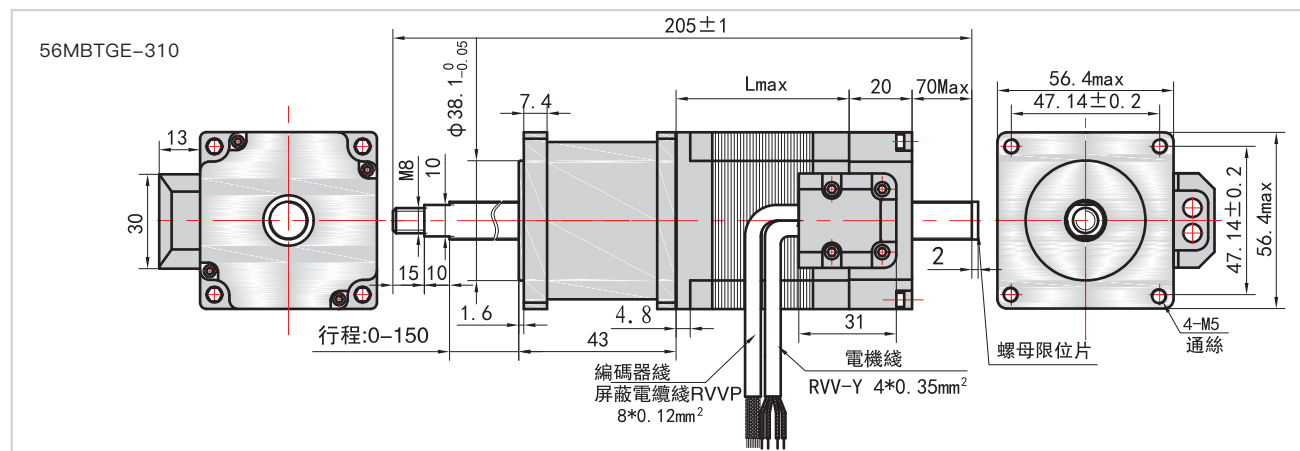

外部驱动式滚珠直线步进电机-86MBG

External Linear Actuator With Ball Screw – NEMA 34

高扭矩nema34混合式步进电机+滚珠丝杠。直接连接无需耦合。提供内置编码器版本。精密线性轴的理想选择

High torque nema34 hybrid stepper motor + ball screw. No coupling is required for direct connection. Built-in encoder version available. Ideal for precision linear axes

Feature

- Integrated ball screw & Nema34 motor 集成滚珠丝杠和Nema34电机
- Longer life and higher accuracy 更长的寿命和更高的精度
- Different lengths available 提供不同长度
- A built-in encoder available. 提供内置编码器。
- Motor Controllers / Drives available 电机控制器/驱动器可用
- 0.0025mm/step with our controller 使用我们的控制器为0.0025mm /步

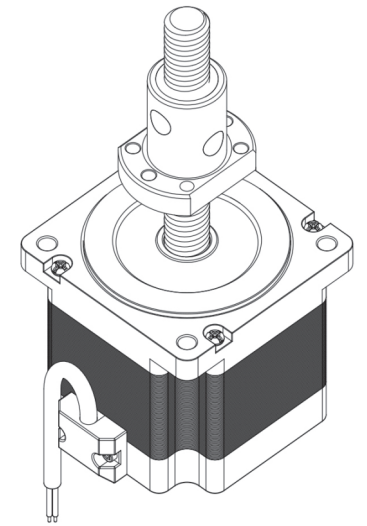

VERSIONS

系列代码 Series models	86H76MBG	86H98MBG
相电流 Current per Winding A	4.0	6.0
静力矩 Holding Torque mN.m	3.5	7.0
相电阻 Resistance per Winding Ohm	0.5	0.4
相电感 Inductance per Winding mH	3.7	3.8
转子惯量 Rotor Inertia gcm ²	1400	1700
电机重量 Weight kg	1.4	2.7
电机高度 Length "L" mm	76	98
螺杆长度 Screw length*L1	Different lengths available	Different lengths available
反馈装置 Feedback	Encoder(Closed-loop version)	Encoder(Closed-loop version)

订货代号 ORDER IDENTIFIER

86H76MBG1605E2000-L1
 MBG0601=Ball Screw code
 丝杠代码

 L1 = Screw length
 丝杠长度

 E2000=Encoder resolution(Optional)
 编码器分辨率 (可选)

可选螺杆 Screw optional

丝杠代码 Screw	直径(mm) Diameter	导程(mm) Screw lead
G1605	16	5
G1610	16	10
G1616	16	16
G2005	20	5
G2020	20	20

可选配件 ACCESSORIES

ZK-ENC-500 Encoder Cable 0.5m
 *Length can be customized
Motor Controllers / Drives

外部驱动式滚珠直线步进电机-86MBG

External Linear Actuator With Ball Screw – NEMA 34

DIMENSIONS (IN MM)

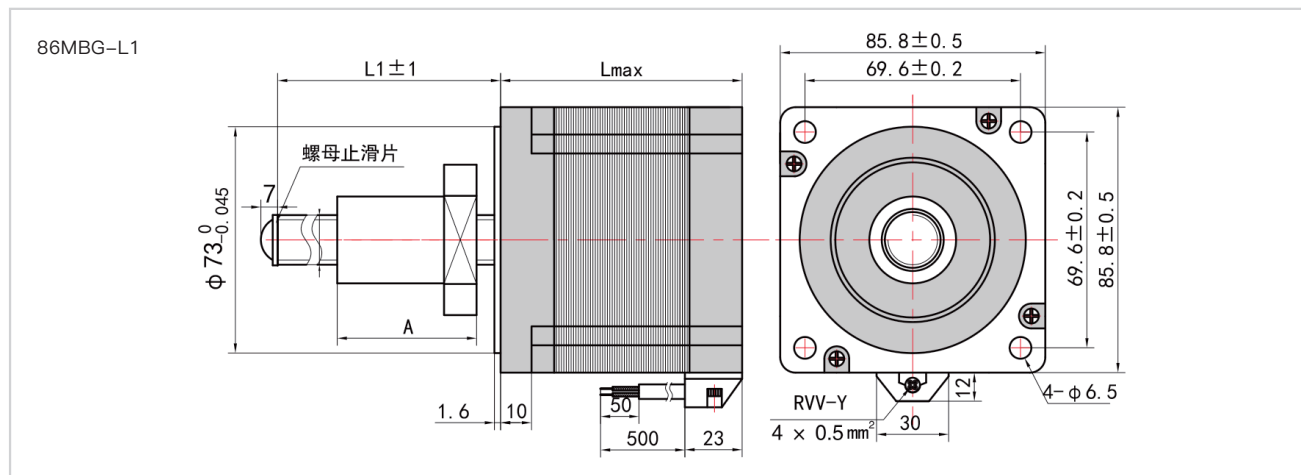

DIMENSIONS WITH ENCODER (IN MM)

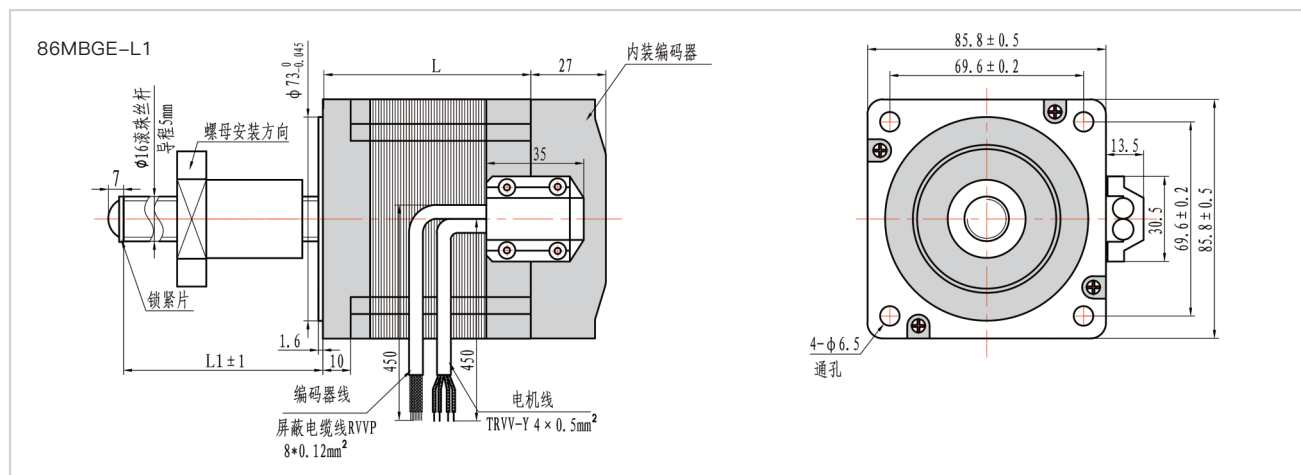

BALL SCREW DIMENSIONS (IN MM)

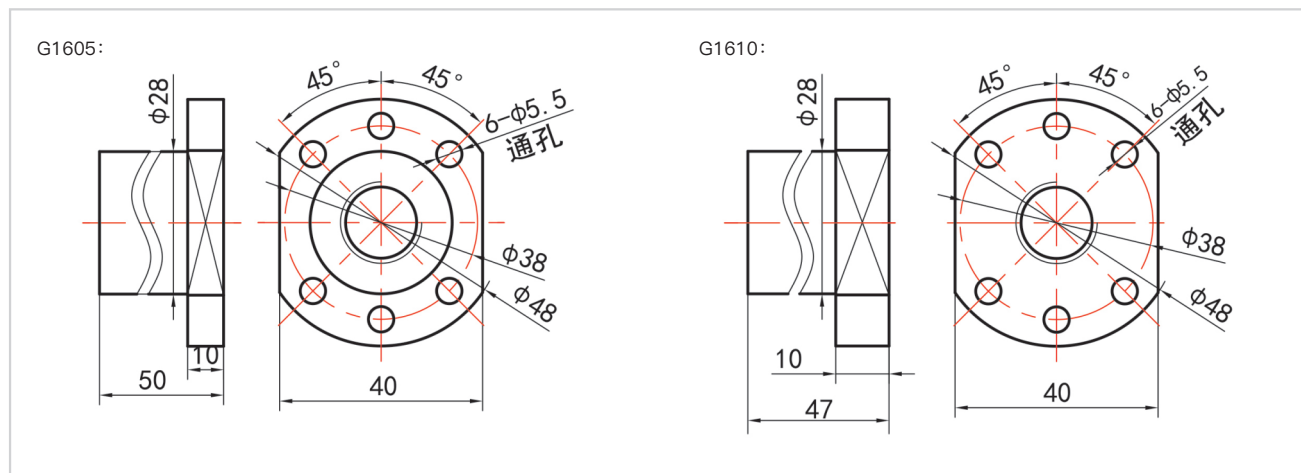

外部驱动式滚珠直线步进电机-86MBG

External Linear Actuator With Ball Screw – NEMA 34

BALL SCREW DIMENSIONS (IN MM)

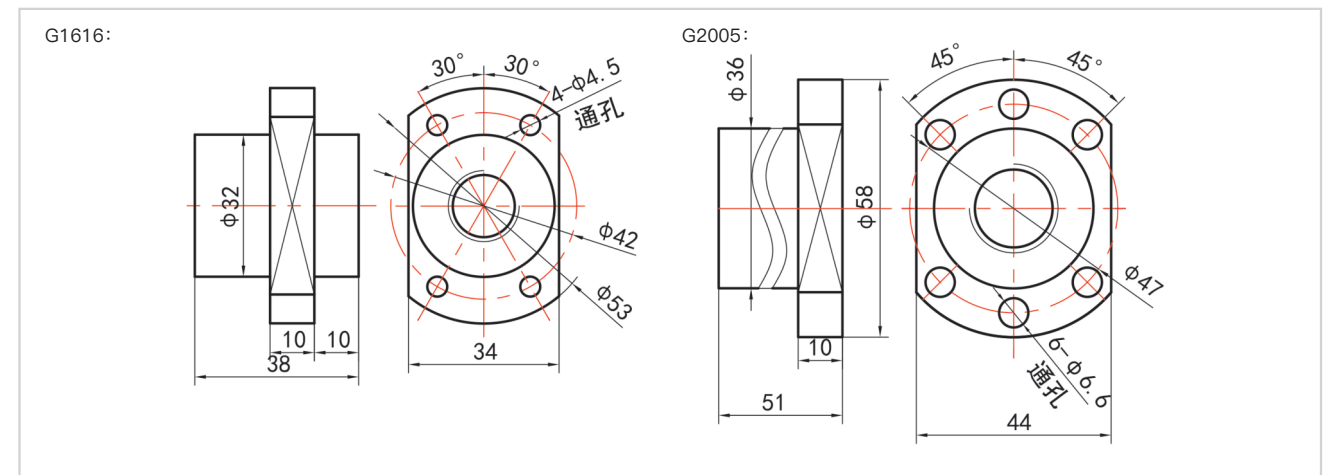

BALL SCREW DIMENSIONS (IN MM)

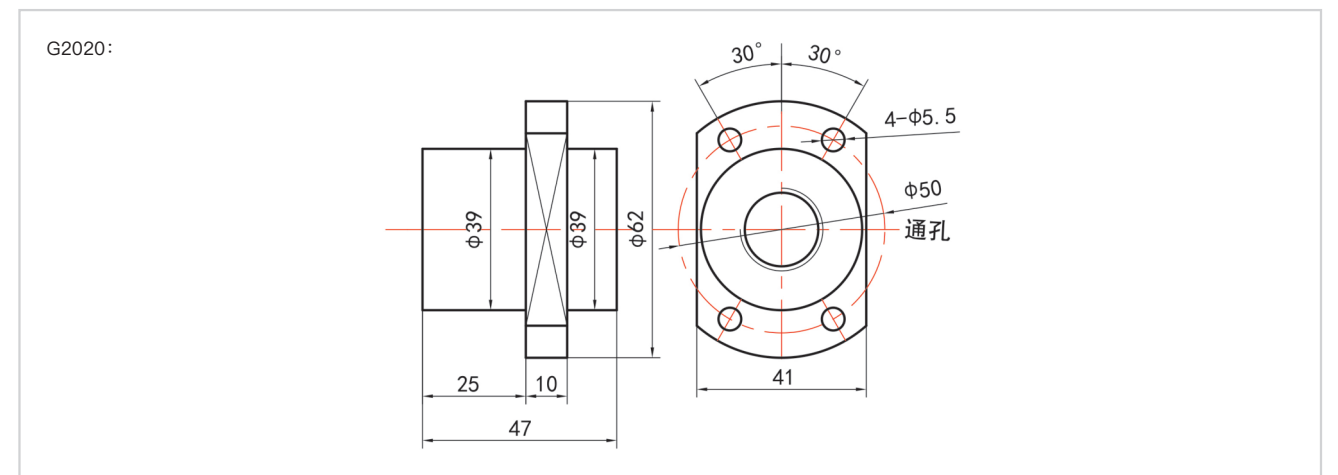

外部驱动式滚珠直线步进电机-86MBG

External Linear Actuator With Ball Screw – NEMA 34

TORQUE CURVE

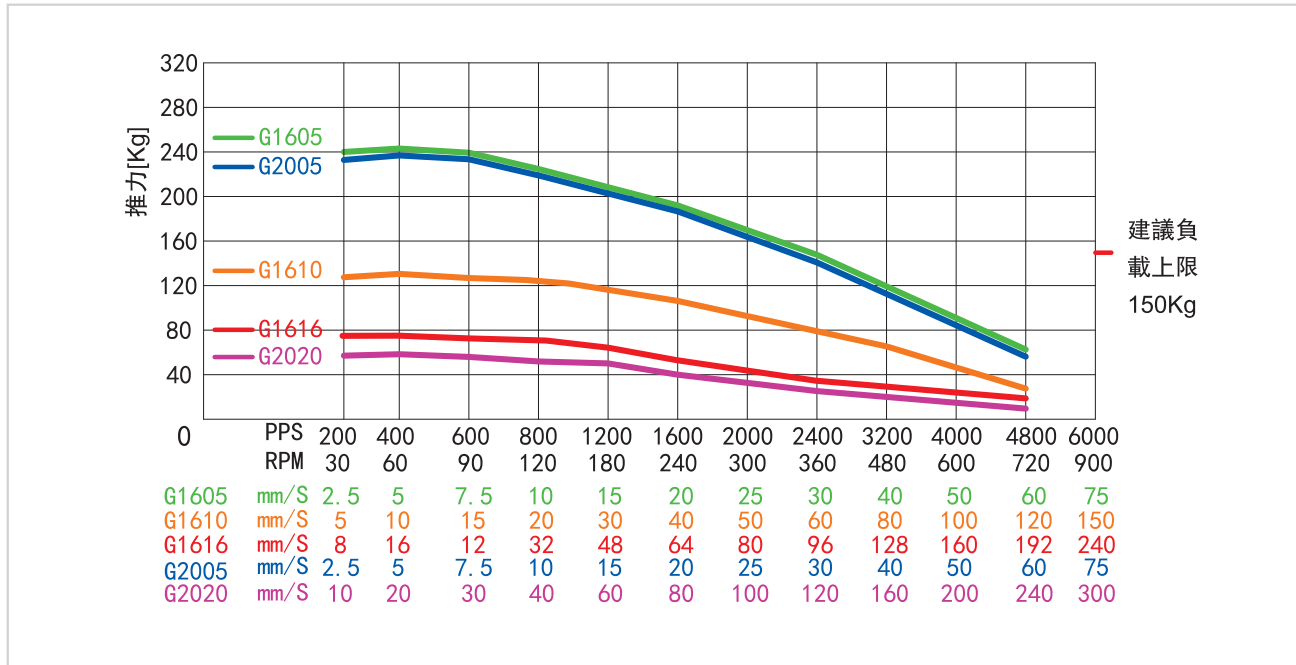

TORQUE CURVE

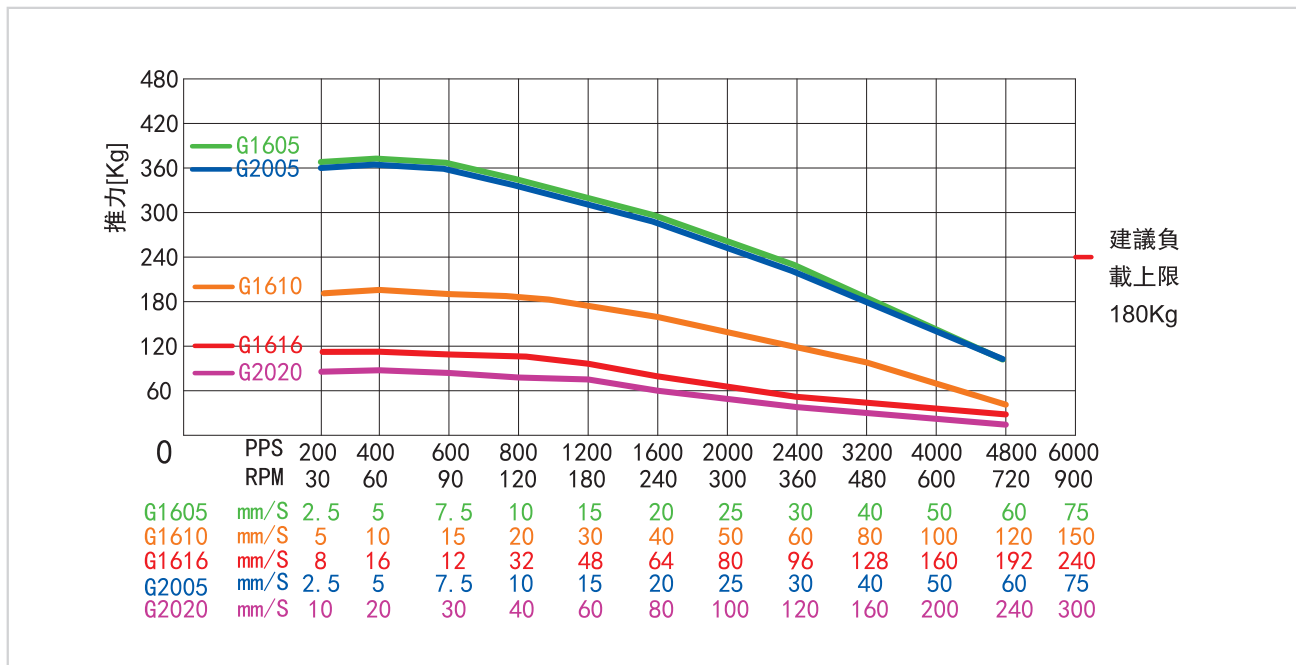

贯通轴式滚珠直线步进电机-86MBTG

Through-shaft Linear Actuator With Ball Screw – NEMA 34

高扭矩nema34混合式步进电机+滚珠丝杠。直接连接无需耦合。提供内置编码器版本。精密线性轴的理想选择

High torque nema34 hybrid stepper motor + ball screw. No coupling is required for direct connection. Built-in encoder version available. Ideal for precision linear axes

Feature

- Integrated ball screw & Nema34 motor 集成滚珠丝杠和Nema34电机
- Longer life and higher accuracy 更长的寿命和更高的精度
- Different lengths available 提供不同长度
- A built-in encoder available. 提供内置编码器。
- Motor Controllers / Drives available 电机控制器/驱动器可用
- 0.0025mm/step with our controller 使用我们的控制器为0.0025mm /步

VERSIONS

系列代码 Series models	86H76MBTG	86H98MBTG
相电流 Current per Winding A	4.0	6.0
静力矩 Holding Torque mN.m	3500	7000
相电阻 Resistance per Winding Ohm	0.5	0.4
相电感 Inductance per Winding mH	3.7	3.8
转子惯量 Rotor Inertia gcm ²	1400	1700
电机重量 Weight kg	1.4	2.7
电机高度 Length "L" mm	76	98
螺杆长度 Screw length*L1	Different lengths available	Different lengths available
反馈装置 Feedback	Encoder(Closed-loop version)	Encoder(Closed-loop version)

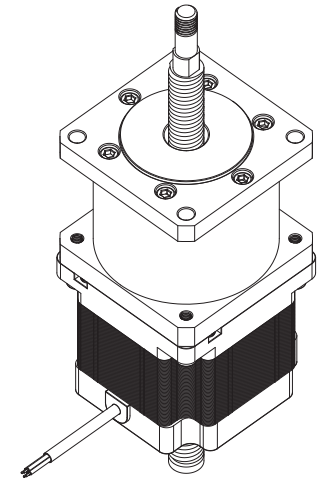

订货代号 ORDER IDENTIFIER

86H76MBTG1605E2000-L1
 MBG0601=Ball Screw code
 丝杠代码
 L1 = Screw length
 丝杠长度

可选螺杆 Screw optional

丝杠代码 Screw	直径(mm) Diameter	导程(mm) Screw lead
G1605	16	5
G1610	16	10

可选配件 ACCESSORIES

Motor Controllers / Drives

DIMENSIONS (IN MM)

