

60mm系列直流无刷电机

Brushless DC Motors – Nema24

DIMENSIONS (IN MM)

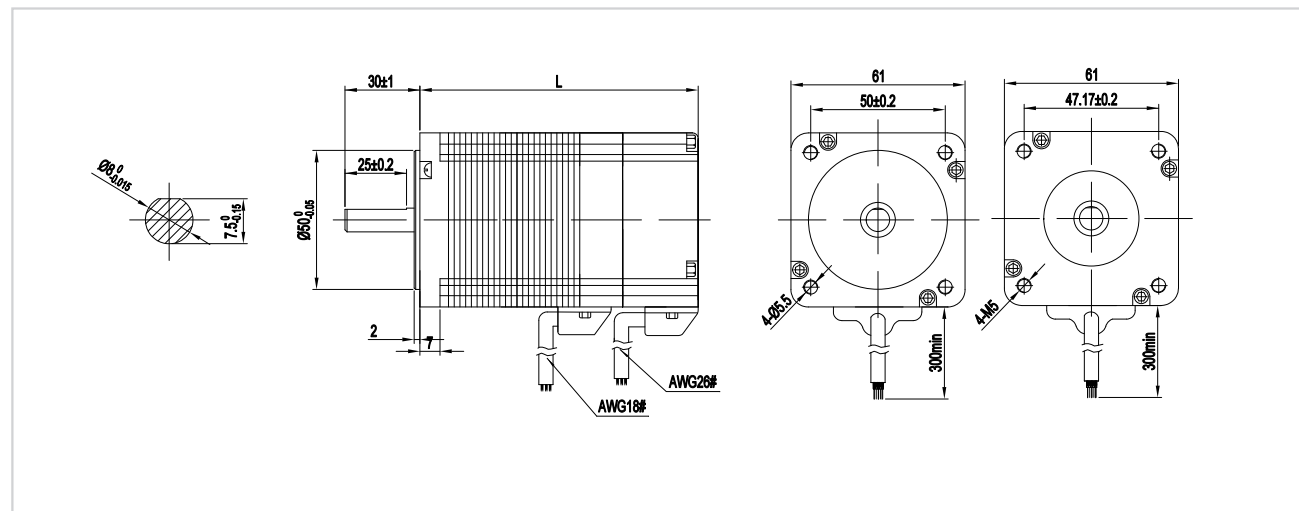

86mm系列直流无刷电机

Brushless DC Motors – Nema34

内转子电机是一款三相直流无刷电机，带永久磁铁的转子在绕有线圈的固定定子内部围绕一个轴旋转。其优点是转子的转动惯量更小且散热性能更佳。这种电机特别适用于高速应用场合。

The inner rotor motor is a three-phase brushless DC motor. The rotor with permanent magnet rotates around a shaft in a fixed stator wound with coils. The utility model has the advantages of smaller moment of inertia of the rotor and better heat dissipation performance. This motor is especially suitable for high-speed applications.



Feature

- 86mm small size 86mm尺寸
- Encoder optional 可配套编码器
- Longer life and higher accuracy 更长的寿命和更高的精度
- Different lengths available 提供不同长度
- Motor Controllers / Drives available 电机控制器/驱动器可用

另有超短伺服版本可选

VERSIONS

型号 Model	YL86BL7008200	YL86BL8008300	YL86BL9008400	YL86BL10508600
极数 Number of poles	8			
相数 Number of phases	3			
额定电压 Nominal voltage VDC	24	48	48	48
额定转速 Rated speed RPM	3000	3000	3000	3000
额定扭矩 Rated torque N-M	0.7	1	1.3	1.8
额定电流 Rated current Amps	6.5	8.5	12	17
输出功率 Output power W	200	300	400	600
峰值扭矩 Peak torque N-M	1.95	2.85	3.9	5.85
峰值电流 Peak current Amps	19.5	25.5	36	51
力矩常数 Torque constant N-M/A	0.06	0.12	0.12	0.124
反电势常数 Back EMF V/KRPM	6.3	12.6	12.6	12.5
机身长度 Body length mm (L)	70	80	90	105
重量 Mass (kg)	1.8	2.3	2.9	3.4

订货代号 ORDER IDENTIFIER

YL86BL7008200

YL86BL=86mm bldc motor 86mm直流无刷电机
70=Body Length(mm) 电机高度 (mm)

- A=单出轴 Single output shaft
- B=双出轴 Front and rear output shaft
- E=集成编码器 Within encoder

可选版本 optional

- A=单出轴 Single output shaft
- B=双出轴 Front and rear output shaft
- E=带编码器版本 Within encoder
丰富的编码器分辨率可选
Rich encoder resolution options

可选配件 ACCESSORIES

- Motor Controllers / Drives
电机驱动与控制器
- Encoder 编码器

86mm系列直流无刷电机

Brushless DC Motors – Nema34

DIMENSIONS (IN MM)

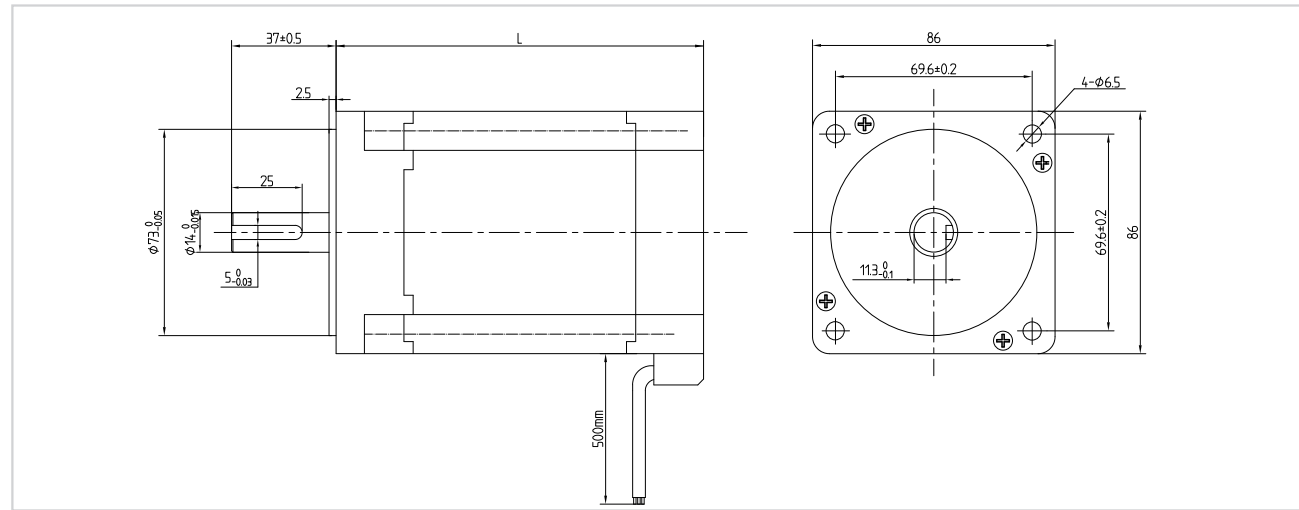

86mm系列力矩增强直流无刷电机

Brushless DC Motors – Nema34

内转子电机是一款三相直流无刷电机，带永久磁铁的转子在绕有线圈的固定定子里面围绕一个轴旋转。其优点是转子的转动惯量更小且散热性能更佳。这种电机特别适用于高速应用场合。

The inner rotor motor is a three-phase brushless DC motor. The rotor with permanent magnet rotates around a shaft in a fixed stator wound with coils. The utility model has the advantages of smaller moment of inertia of the rotor and better heat dissipation performance. This motor is especially suitable for high-speed applications.



Feature

- 86mm small size 86mm尺寸
- Encoder optional 可配套编码器
- Longer life and higher accuracy 更长的寿命和更高的精度
- Different lengths available 提供不同长度
- Motor Controllers / Drives available 电机控制器/驱动器可用

另有超短伺服版本可选

VERSIONS

型号 Model	YL86BL8004314	YL86BL10504565	YL86BL11504659	YL86BL13004789	YL86BL13004785
极数 Number of Poles	4	4	4	4	4
相数 Number of Phases	3	3	3	3	3
额定电压 Nominal voltage VDC	48	48	48	48	310
额定转速 Rated speed RPM	3000	3000	3000	3000	3000
额定扭矩 Rated Torque N-m	1	1.8	2.1	2.5	2.5
额定电流 Rated Current Amps	8.5	14.8	17	19.5	4
输出功率 Output Power Watts	314	565	659	789	785
峰值扭矩 Peak Torque N-m	3	5.4	6.3	7.5	7.5
峰值电流 Peak Current Amps	25	42	51	55	12
力矩常数 Torque constant N-m/A	0.131	0.131	0.127	0.127	0.127
反电势常数 Back EMF V/k RPM	13.7	13.7	13.3	13.3	13.3
转动惯量 Rotor inertia g·cm ²	120	230	266	320	320
电机长度 Body Length (L) mm	80	105	115	130	130
重量 Mass kg	2.3	3.4	3.8	4.3	4.3

订货代号 ORDER IDENTIFIER

YL86BL8004314

YL86BL=86mm bldc motor 80mm 直流无刷电机
80=Body Length(mm) 电机高度 (mm)

A=单出轴 Single output shaft
B=双出轴 Front and rear output shaft
E=集成编码器 Within encoder

可选版本 optional

A=单出轴 Single output shaft
B=双出轴 Front and rear output shaft
E=带编码器版本 Within encoder
丰富的编码器分辨率可选
Rich encoder resolution options

可选配件 ACCESSORIES

Motor Controllers / Drives
电机驱动与控制器
Encoder 编码器