

## 57mm系列直流无刷电机

Brushless DC Motors – Nema23

### DIMENSIONS (IN MM)

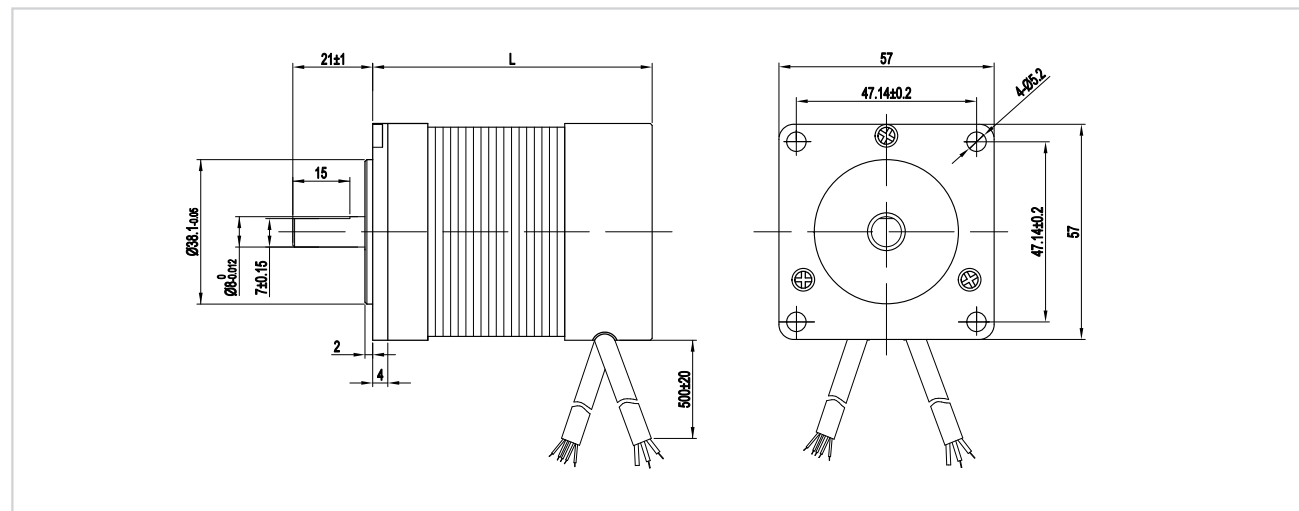

## 60mm系列直流无刷电机

Brushless DC Motors – Nema24

内转子电机是一款三相直流无刷电机，带永久磁铁的转子在绕有线圈的固定定子里面围绕一个轴旋转。其优点是转子的转动惯量更小且散热性能更佳。这种电机特别适用于高速应用场合。

The inner rotor motor is a three-phase brushless DC motor. The rotor with permanent magnet rotates around a shaft in a fixed stator wound with coils. The utility model has advantages of smaller moment of inertia of the rotor and better heat dissipation performance. This motor is especially suitable for high-speed applications.

### Feature

- 60mm small size 60mm尺寸
- Encoder optional 可配套编码器
- Longer life and higher accuracy 更长的寿命和更高的精度
- Different lengths available 提供不同长度
- Motor Controllers / Drives available 电机控制器/驱动器可用



另有超短伺服版本可选

### VERSIONS

型号 Model	YL60BL7808100	YL60BL9908200	YL60BL12008400	YL60BL14008400
极数 Number of Poles	8	8	8	8
相数 Number of Phases	3	3	3	3
额定电压 Nominal voltage VDC	48	48	48	48
额定转速 Rated speed RPM	3000	3000	3000	3000
额定扭矩 Rated Torque N-m	0.32	0.65	0.95	1.28
额定电流 Rated Current Amps	5.5	6.5	9.5	12
输出功率 Output Power Watts	100	200	300	400
峰值扭矩 Peak Torque N-m	0.96	1.95	2.85	3.84
峰值电流 Peak Current Amps	16.5	19.5	28.5	36
力矩常数 Torque constant N-m/A	0.06	0.06	0.09	0.12
反电势常数 Back EMF V/k RPM	4.2	4.2	6.4	8.4
转动惯量 Rotor inertia kg·cm <sup>2</sup>	0.24	0.48	0.72	0.96
电机长度 Body Length (L) mm	78	99	120	140
重量 Mass kg	0.85	1.25	1.65	2.05

### 订货代号 ORDER IDENTIFIER

#### YL60BL7808100-A/B

YL60BL=60mm bldc motor 60mm直流无刷电机  
78=Body Length(mm) 电机高度 (mm)

A=单出轴 Single output shaft  
B=双出轴 Front and rear output shaft  
E=集成编码器 Within encoder

### 可选版本 optional

A=单出轴 Single output shaft  
B=双出轴 Front and rear output shaft  
E=带编码器版本 Within encoder  
丰富的编码器分辨率可选  
Rich encoder resolution options

### 可选配件 ACCESSORIES

Motor Controllers / Drives  
电机驱动与控制器  
Encoder 编码器

## 60mm系列直流无刷电机

Brushless DC Motors – Nema24

### DIMENSIONS (IN MM)

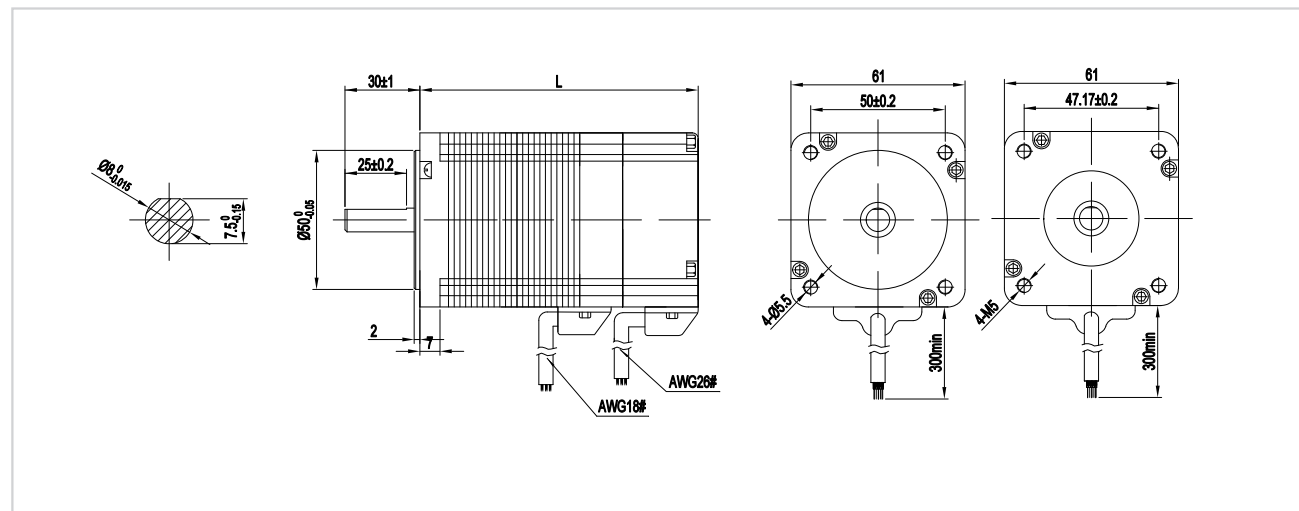

## 86mm系列直流无刷电机

Brushless DC Motors – Nema34

内转子电机是一款三相直流无刷电机，带永久磁铁的转子在绕有线圈的固定定子内部围绕一个轴旋转。其优点是转子的转动惯量更小且散热性能更佳。这种电机特别适用于高速应用场合。

The inner rotor motor is a three-phase brushless DC motor. The rotor with permanent magnet rotates around a shaft in a fixed stator wound with coils. The utility model has the advantages of smaller moment of inertia of the rotor and better heat dissipation performance. This motor is especially suitable for high-speed applications.



### Feature

- 86mm small size 86mm尺寸
- Encoder optional 可配套编码器
- Longer life and higher accuracy 更长的寿命和更高的精度
- Different lengths available 提供不同长度
- Motor Controllers / Drives available 电机控制器/驱动器可用

另有超短伺服版本可选

### VERSIONS

型号 Model	YL86BL7008200	YL86BL8008300	YL86BL9008400	YL86BL10508600
极数 Number of poles	8			
相数 Number of phases	3			
额定电压 Nominal voltage VDC	24	48	48	48
额定转速 Rated speed RPM	3000	3000	3000	3000
额定扭矩 Rated torque N-M	0.7	1	1.3	1.8
额定电流 Rated current Amps	6.5	8.5	12	17
输出功率 Output power W	200	300	400	600
峰值扭矩 Peak torque N-M	1.95	2.85	3.9	5.85
峰值电流 Peak current Amps	19.5	25.5	36	51
力矩常数 Torque constant N-M/A	0.06	0.12	0.12	0.124
反电势常数 Back EMF V/KRPM	6.3	12.6	12.6	12.5
机身长度 Body length mm (L)	70	80	90	105
重量 Mass (kg)	1.8	2.3	2.9	3.4

### 订货代号 ORDER IDENTIFIER

#### YL86BL7008200

YL86BL=86mm bldc motor 86mm直流无刷电机  
70=Body Length(mm) 电机高度 (mm)

- A=单出轴 Single output shaft
- B=双出轴 Front and rear output shaft
- E=集成编码器 Within encoder

### 可选版本 optional

- A=单出轴 Single output shaft
- B=双出轴 Front and rear output shaft
- E=带编码器版本 Within encoder  
丰富的编码器分辨率可选  
Rich encoder resolution options

### 可选配件 ACCESSORIES

- Motor Controllers / Drives  
电机驱动与控制器
- Encoder 编码器