

42系列贯通式直线电机-17HSL

Through-shaft Linear Actuator With T-Screw – NEMA17

DIMENSIONS (IN MM)

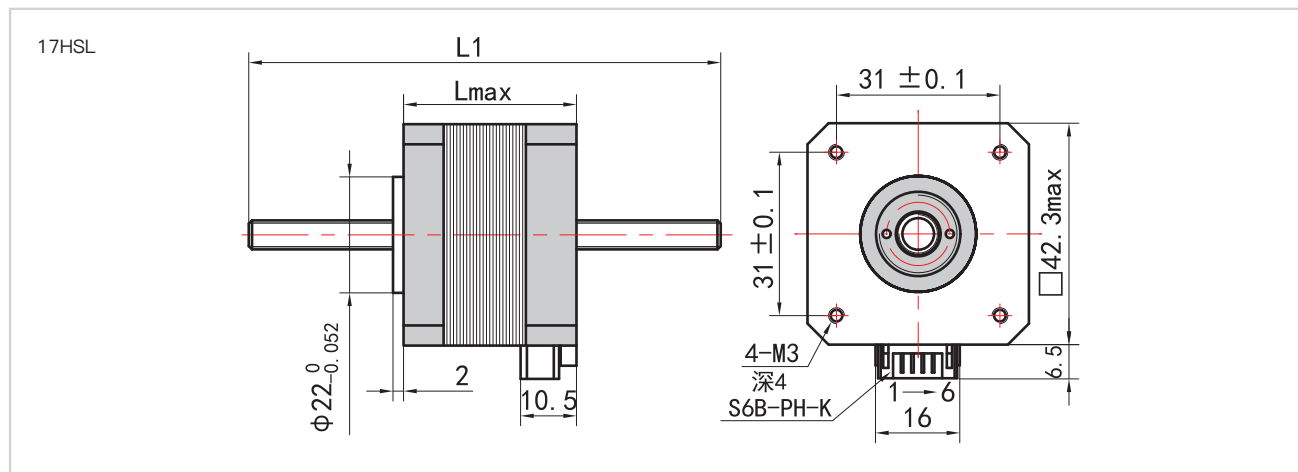

DIMENSIONS (IN MM)

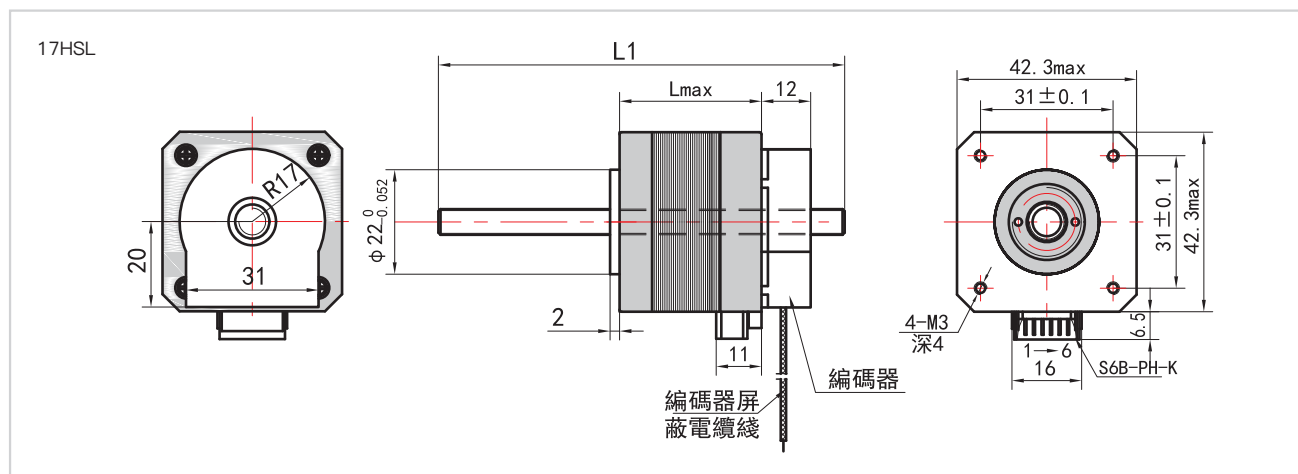

42系列固定轴式直线电机-17HSA

Fixed shaft Linear Actuator With T-Screw – NEMA 17

灵活的紧凑型直线步进电机，尺寸为 NEMA 17 (42 mm)，定位时间短、推力和拉力大。固定轴式，直线输出，无需额外结构设计。

Flexible compact linear stepper motor, size NEMA 17 (42 mm), short positioning time, high thrust and pull. Fixed shaft type, linear output, no additional structural design is required.

Feature

- External Linear linear actuator 固定轴式线性执行器
- 20mm small size 42系列法兰
- Encoder optional 可配套编码器
- Longer life and higher accuracy 更长的寿命和更高的精度
- Different lengths available 提供不同长度
- Motor Controllers / Drives available 电机控制器和驱动器可用

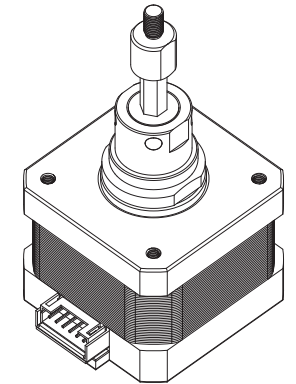

VERSIONS

系列代码 Series models	17HS34A	17HS48A
相电流 Current per Winding A	1.5	1.5
静力矩 Holding Torque mN.m	260	450
相电阻 Resistance per Winding Ohm	1.56	2
相电感 Inductance per Winding mH	2.4	3.85
转子惯量 Rotor Inertia gcm ²	38	82
电机重量 Weight kg	0.2	0.34
电机高度 Length "L" mm	34	48
螺杆长度 Screw length*L1	Different lengths available	Different lengths available
反馈装置 Feedback	Encoder(Closed-loop version)	Encoder(Closed-loop version)

订货代号 ORDER IDENTIFIER

17HS34T63502A127-E2000-L1
 T63502=T-Screw code
 丝杠代码
 L1 = Screw length
 丝杠长度
 E2000=Encoder 2000/Resolution
 E2000=编码器 2000刻度

可选螺杆 Screw optional

Screw	Diameter	Screw lead	Step(mm)
T635-1.58	6.35	1.5875	0.007935
T635-2	6.35	2	0.01
T635-3.17	6.35	3.175	0.015875
T635-6.35	6.35	6.35	0.03175
T556-9.75	5.56	9.7536	0.048768

可选配件 ACCESSORIES

Motor Controllers / Drives
 电机驱动与控制器

DIMENSIONS (IN MM)

