

42系列外驱式直线电机-17HS

External Linear Actuator With T-Screw – NEMA 17

Nema17集成梯形丝杠电机，不带联轴器，电机与丝杠直接连接。提供多种电机高度版本。还提供用于位置反馈的内置编码器。

Nema11 integrated T screw motor, without coupling, the motor and screw are directly connected. Two motor height versions available. Screws of different lengths available. A built-in encoder for position feedback is also available.

Feature

- Integrated structure 一体化结构
- Multiple specifications available 提供多种规格
- Longer life and higher accuracy 更长的寿命和更高的精度
- Different lengths available 提供不同长度
- A built-in encoder available. 提供内置编码器。
- Motor Controllers / Drives available 电机控制器/驱动器可用
- 0.0002mm/step with our controlle 使用控制器时, 0.0002mm /步

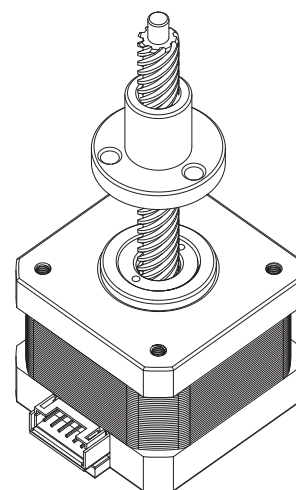

VERSIONS

系列代码 Series models	17HS34	17HS48
相电流 Current per Winding A	1.5	1.5
静力矩 Holding Torque mN.m	260	450
相电阻 Resistance per Winding Ohm	1.56	2
相电感 Inductance per Winding mH	2.4	3.85
转子惯量 Rotor Inertia gcm ²	38	82
电机重量 Weight kg	0.2	0.34
电机高度 Length "L" mm	34	48
螺杆长度 Screw length*L1	Different lengths available	Different lengths available
反馈装置 Feedback	Encoder(Closed-loop version)	Encoder(Closed-loop version)

订货代号 ORDER IDENTIFIER

17HS34T0502E2000-L1

T0502=Screw code
丝杠代码

L1 = Screw length
丝杠长度

E2000=Encoder resolution(Optional)
编码器分辨率 (可选)

可选螺杆 Screw optional

Screw	Diameter	Screw lead	Step(mm)
T635-1.58	6.35	1.5875	0.007935
T635-2	6.35	2	0.01
T635-3.17	6.35	3.175	0.015875
T635-6.35	6.35	6.35	0.03175
T556-9.75	5.56	9.7536	0.048768
T8-20	8	20	0.1

可选配件 ACCESSORIES

ZK-ENC-500 Encoder Cable 0.5m

Encoder: 500-4000PCR

Motor Controllers / Drives

42系列外驱式直线电机-17HS

External Linear Actuator With T-Screw – NEMA 17

DIMENSIONS (IN MM)

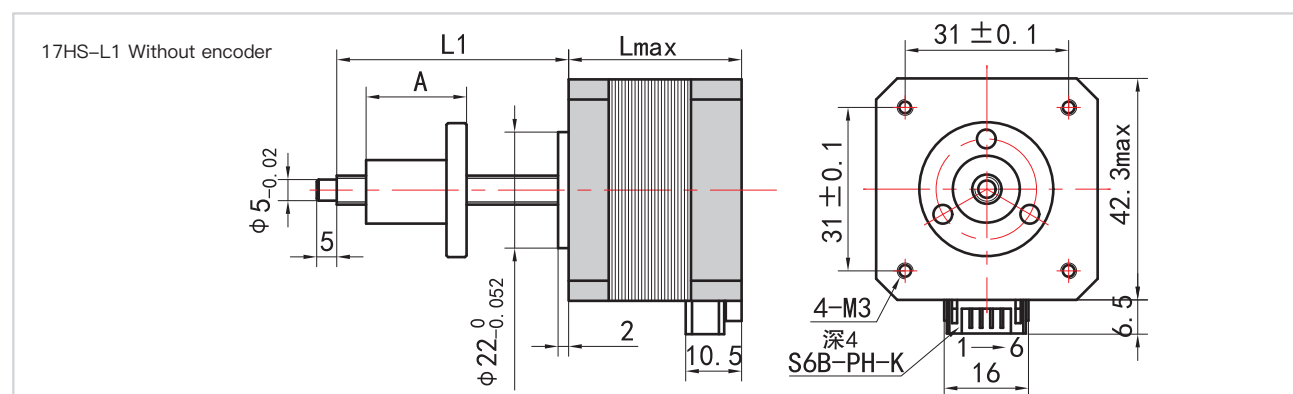

DIMENSIONS (IN MM)

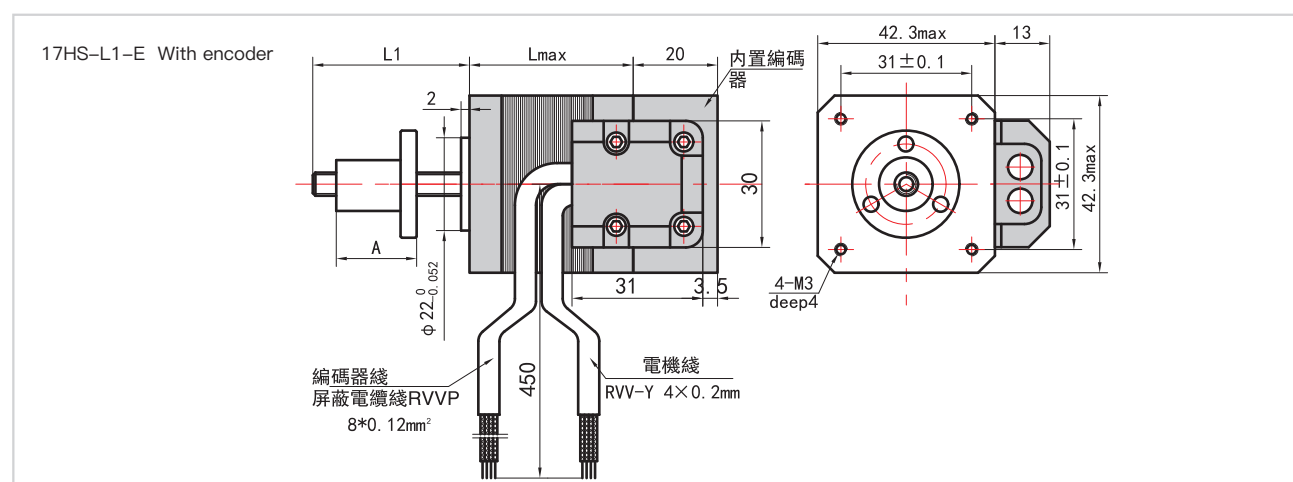

DIMENSIONS (IN MM)

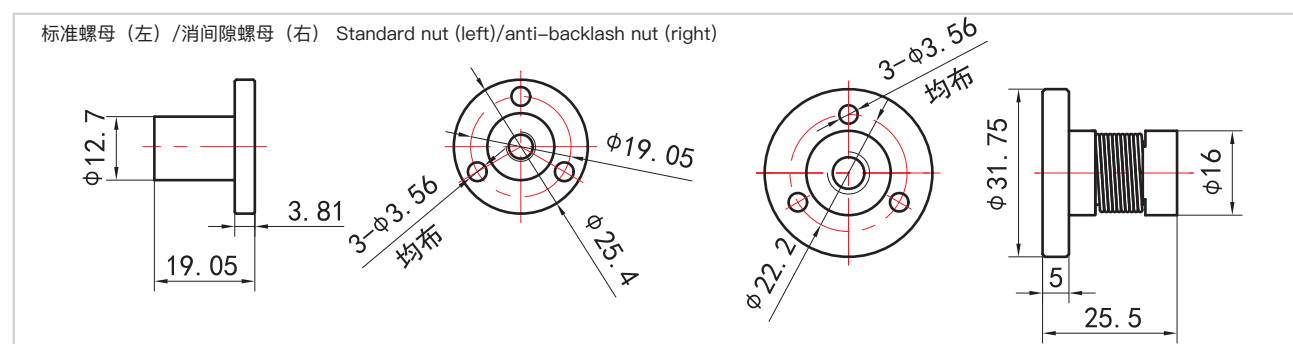

42系列外驱式直线电机-17HS

External Linear Actuator With T-Screw – NEMA 17

Force-Velocity Curve-17HS34

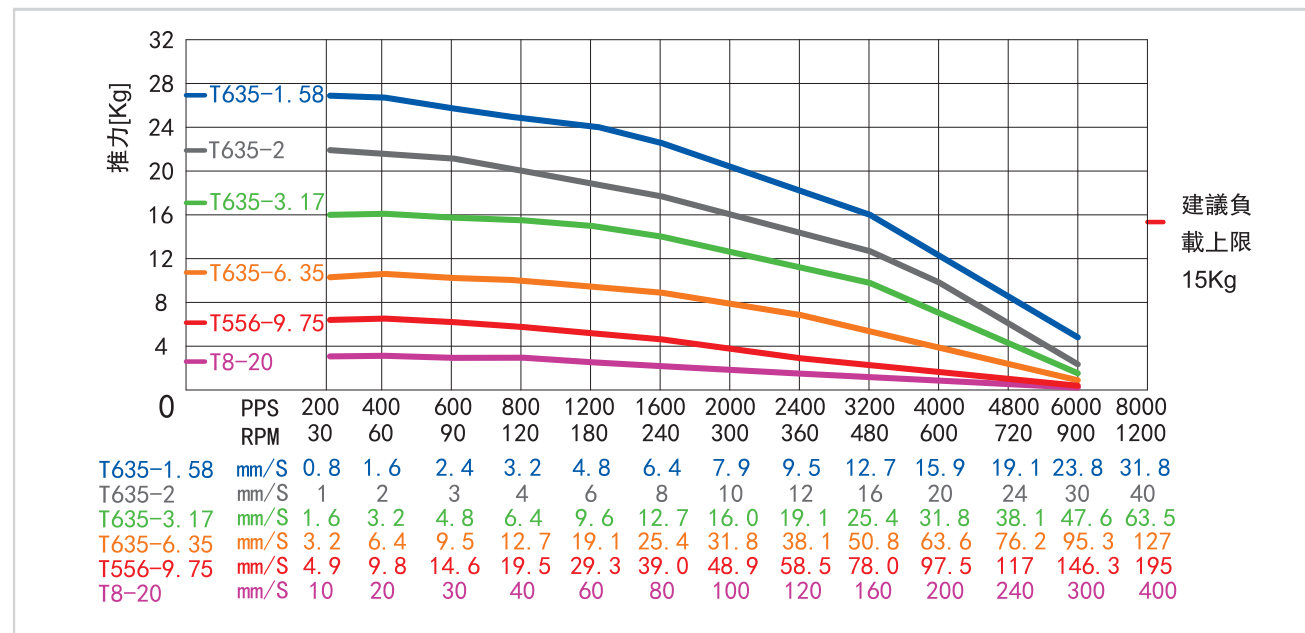

Force-Velocity Curve-17HS48

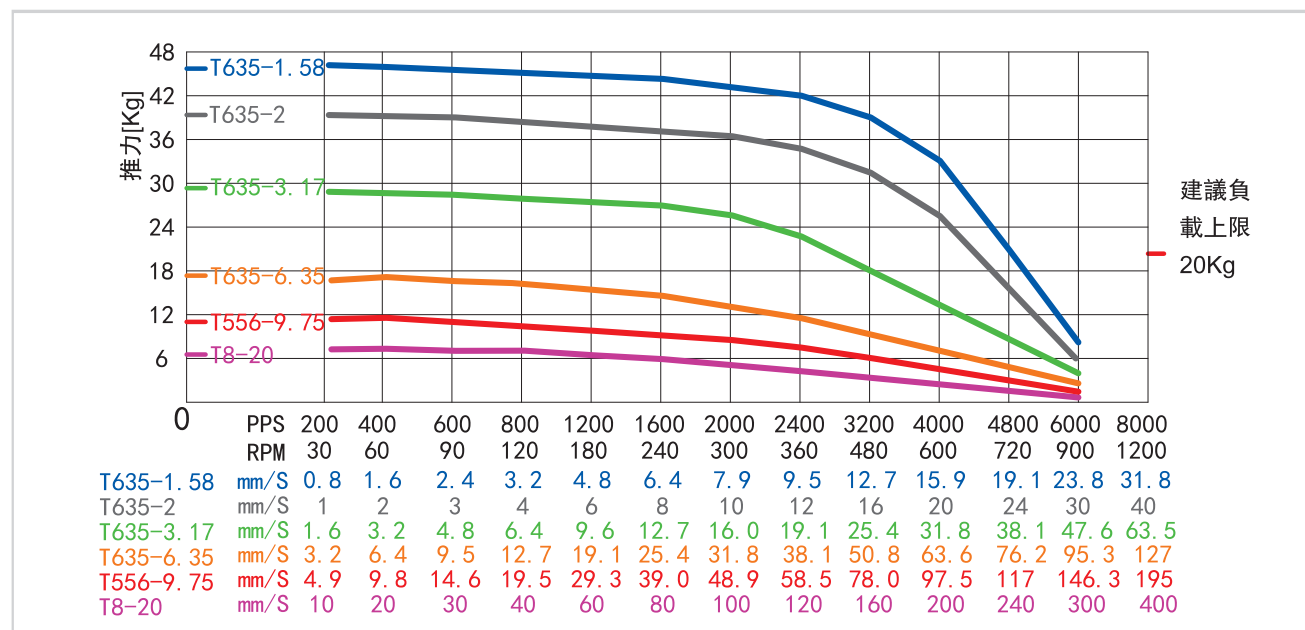

*The closed-loop version will have 10%~20% higher performance.
*Use other brands of drives, safety margin must be greater than the above value 30% to 50%

42系列贯通式直线电机-17HSL

Through-shaft Linear Actuator With T- Screw – NEMA17

NEMA17(42mm法兰)贯通轴式直线电机是贯通式的线性执行器，结构紧凑，传动效率和定位精度高。可选装高分辨率的贯通编码器配合高定位使用
Nema17 through-axis linear actuators integrate T screws and two-phase stepper motors. Additional encoder can also provide

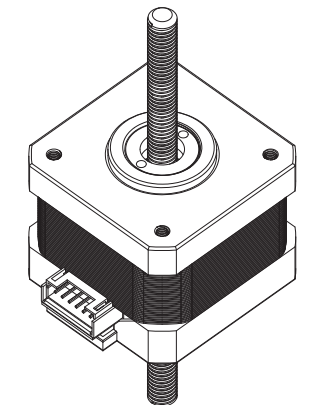

Feature

- Integrated structure 一体化结构
- Multiple specifications available 提供多种规格
- Longer life and higher accuracy 更长的寿命和更高的精度
- Different lengths available 提供不同长度
- A built-in encoder available. 提供内置编码器。
- Motor Controllers / Drives available 电机控制器/驱动器可用
- 0.0002mm/step with our controlle 使用控制器时, 0.0002mm /步

VERSIONS

系列代码 Series models	17HS34L	17HS48L
相电流 Current per Winding A	1.5	1.5
静力矩 Holding Torque mN.m	260	450
相电阻 Resistance per Winding Ohm	1.56	2
相电感 Inductance per Winding mH	2.4	3.85
转子惯量 Rotor Inertia gcm ²	38	82
电机重量 Weight kg	0.2	0.34
电机高度 Length "L" mm	34	48
螺杆长度 Screw length*L1	Different lengths available	Different lengths available
反馈装置 Feedback	Encoder(Closed-loop version)	Encoder(Closed-loop version)

订货代号 ORDER IDENTIFIER

17HS34LT63502E2000-L1

T63502=Screw code
丝杠代码

L1 = Screw length
丝杠长度

E2000=Encoder resolution(Optional)
编码器分辨率 (可选)

可选螺杆 Screw optional

Screw	Diameter	Screw lead	Step(mm)
T635-1.58	6.35	1.5875	0.007935
T635-2	6.35	2	0.01
T635-3.17	6.35	3.175	0.015875
T635-6.35	6.35	6.35	0.03175
T556-9.75	5.56	9.7536	0.048768

可选配件 ACCESSORIES

ZK-ENC-500 Encoder Cable 0.5m

Encoder: 500-4000PCR

Motor Controllers / Drives