

# 35系列步进电机-14HS

Stepper Motors – NEMA 14

14HS混合式步进电机是35mm安装法兰的两相步进电机，提供多种长度和不同的绕组，可选装结构紧凑的高精度编码器。

Flexible and compact stepper motor, size NEMA 14 (35 mm) . Provide multiple lengths and different windings. A compact high-precision encoder is optional.

## Feature

- Micro stepper motor 微型步进电机
- 35mm size 35系列法兰
- Encoder optional 可配套编码器
- Longer life and higher accuracy 更长的寿命和更高的精度
- Different lengths available 提供不同长度
- Motor Controllers / Drives available 电机控制器/驱动器可用

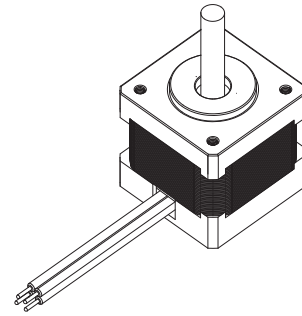

## VERSIONS

| 系列代码 Series models                  | 14HS34   | 14HS48 |
|-------------------------------------|--|--------|
| 相电流 Current per Winding A           | 1.0  | 1.5    |
| 静力矩 Holding Torque mN.m             | 160  | 320    |
| 相电阻 Resistance per Winding Ohm      | 2.7  | 2.3    |
| 相电感 Inductance per Winding mH       | 3.0  | 2.8    |
| 转子惯量 Rotor Inertia gcm <sup>2</sup> | 18   | 26     |
| 电机重量 Weight kg                      | 0.18   | 0.28   |
| 电机高度 Length "L" mm                  | 34   | 48     |
| 电机法兰 Motor flange mm                | 35   | 35     |
| 反馈装置 Feedback                       | Encoder(Closed-loop version) 500/1000/2000/4000 CPR Optional |        |

## 订货代号 ORDER IDENTIFIER

**14HS34-E2000-R5**  
 14HS34=Motor body code  
 电机代号  
 E2000=Encoder 2000/Resolution  
 E2000=编码器 2000刻度  
 R=圆出轴  
 D=扁出轴

## 可选线缆 Cable optional

ZK-ENC-L500 编码器线缆  
 ZK-M 出线定制,用户需提供完整定制信息

## 可选配件 ACCESSORIES

Motor Controllers / Drives电机驱动控制器  
 Encoder 编码器  
 Gearbox 齿轮箱

## DIMENSIONS (IN MM)

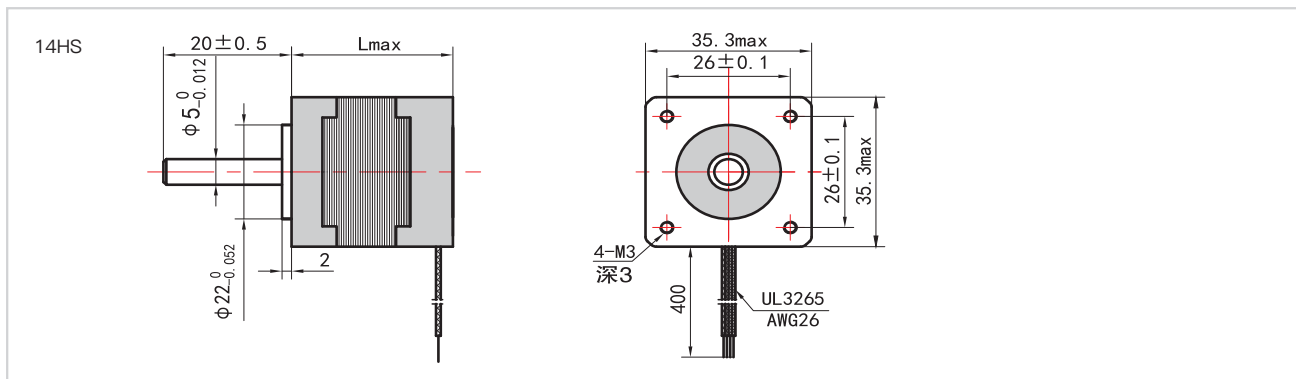

# 35系列步进电机-14HS

Stepper Motors – NEMA 14

## DIMENSIONS (IN MM)

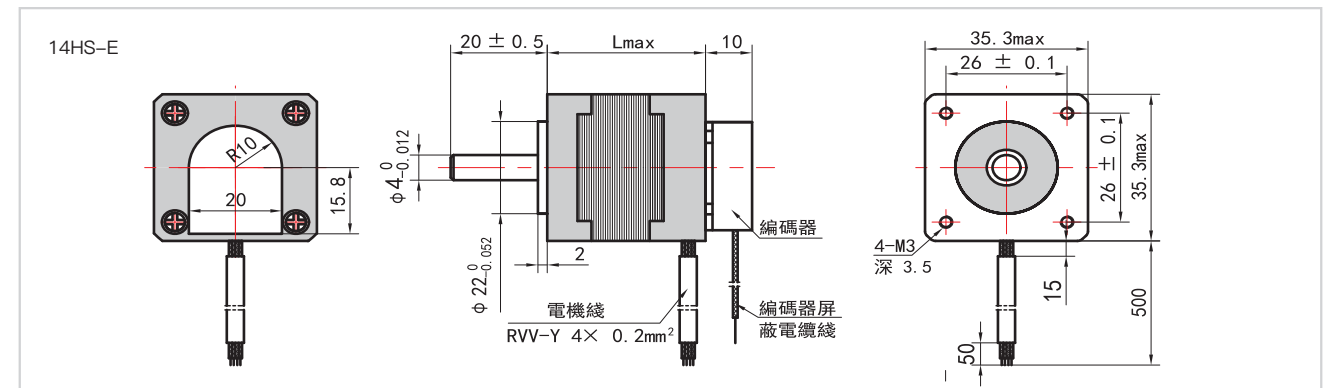

## TORQUE (IN Nm)

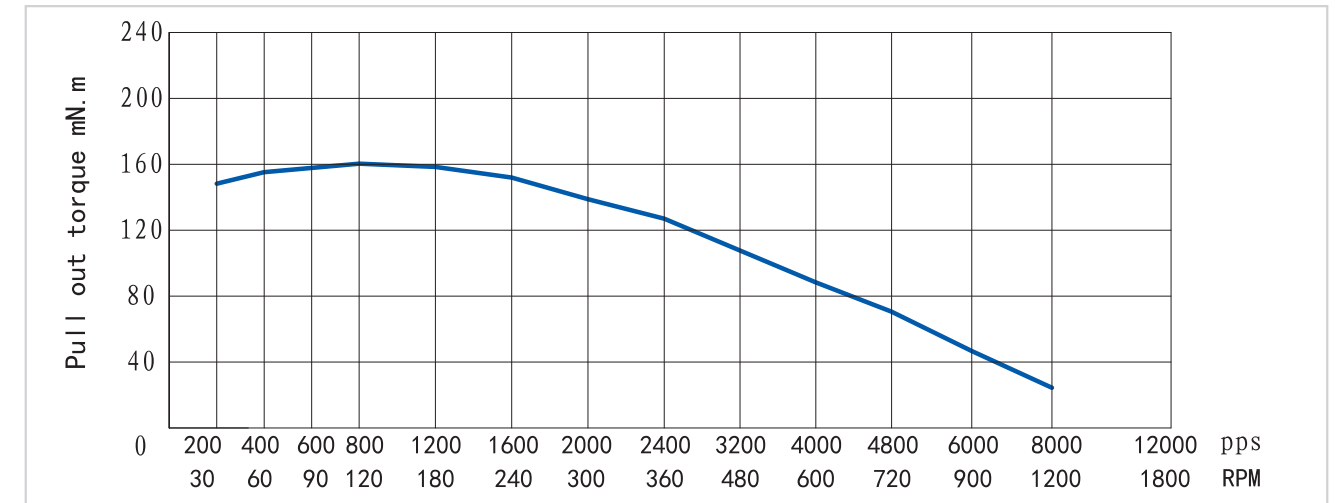

## TORQUE (IN Nm)

