

35法兰外部驱动式线性执行器-14HS

External Linear Actuator With T-Screw – NEMA 14

灵活的紧凑型直线步进电机，尺寸为 NEMA 14 (35 mm)，定位时间短、推力和拉力大。带有梯形螺纹。提供多种长度和不同的绕组。

Flexible and compact linear stepper motor, size NEMA 14 (35 mm), short positioning time, high thrust and pull. The threaded nut is injection molded into the hollow shaft with a trapezoidal thread. Provide multiple lengths and different windings.

Feature

- External Linear linear actuator 外驱式线性执行器
- 35mm size 35系列法兰
- Encoder optional 可配套编码器
- Longer life and higher accuracy 更长的寿命和更高的精度
- Different lengths available 提供不同长度
- Motor Controllers / Drives available 电机控制器/驱动器可用

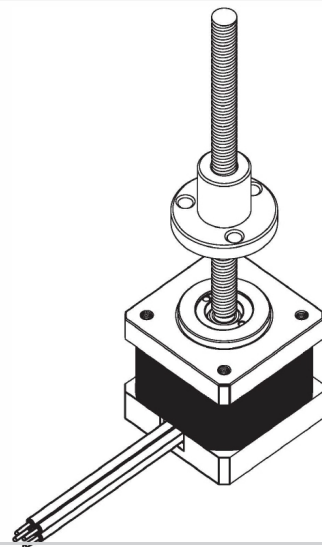

VERSIONS

系列代码 Series models	14HS34
相电流 Current per Winding A	1.0
静力矩 Holding Torque mN.m	160
相电阻 Resistance per Winding Ohm	2.7
相电感 Inductance per Winding mH	3.0
转子惯量 Rotor Inertia gcm ²	18
电机重量 Weight kg	0.18
电机高度 Length "L" mm	34
螺杆长度 Screw length*L1	Different lengths available
反馈装置 Feedback	Encoder(Closed-loop version)

订货代号 ORDER IDENTIFIER

14HS34T63502-E2000-L1

T63502=T-Screw code

丝杠代码

L1 = Screw length

丝杠长度

E2000=Encoder 2000/Resolution

E2000=编码器 2000刻度

可选螺杆 Screw optional

Screw	Diameter	Screw lead	Step(mm)
T635-1.58	6.35	1.5875	0.007935
T635-2	6.35	2	0.01
T635-3.17	6.35	3.175	0.015875
T635-6.35	6.35	6.35	0.03175
T556-9.75	5.56	9.7536	0.048768
T8-20	8	20	0.1

可选配件 ACCESSORIES

Motor Controllers / Drives
电机驱动与控制器

Standard nut 标准螺母

Clearance nut 消间隙螺母

DIMENSIONS (IN MM)

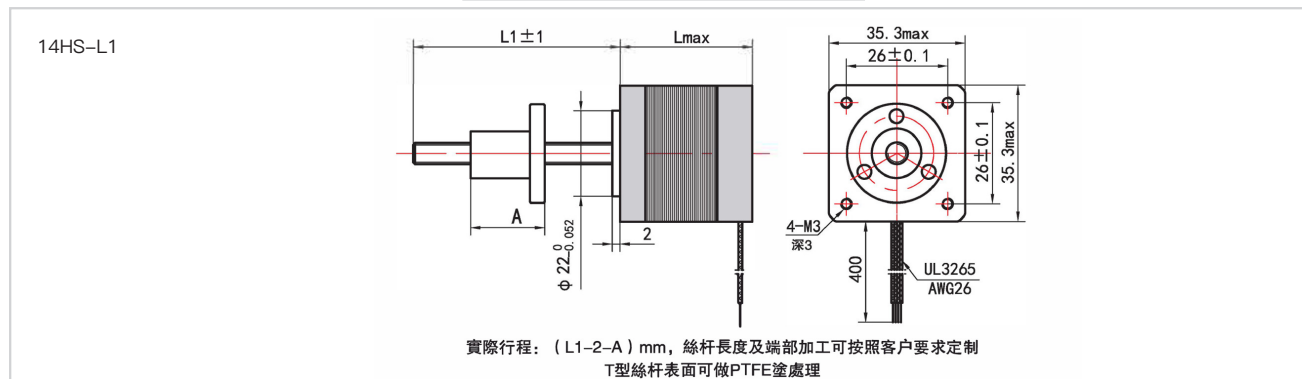

35法兰外部驱动式线性执行器-14HS

External Linear Actuator With T-Screw – NEMA 14

DIMENSIONS (IN MM)

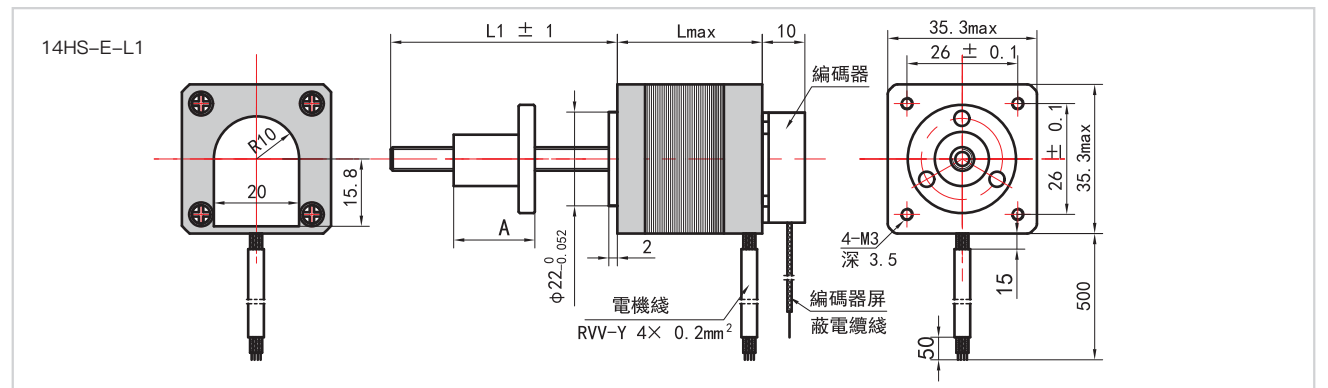

DIMENSIONS (IN MM)

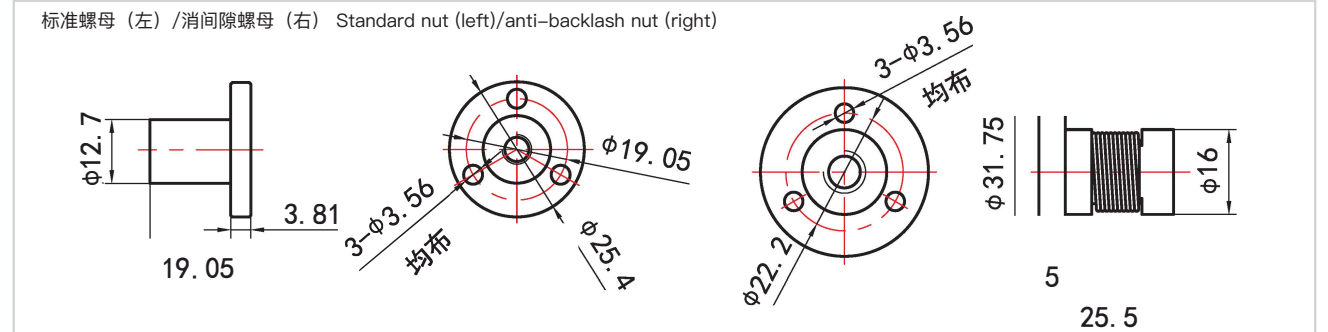

Force-Velocity Curve-11HY40

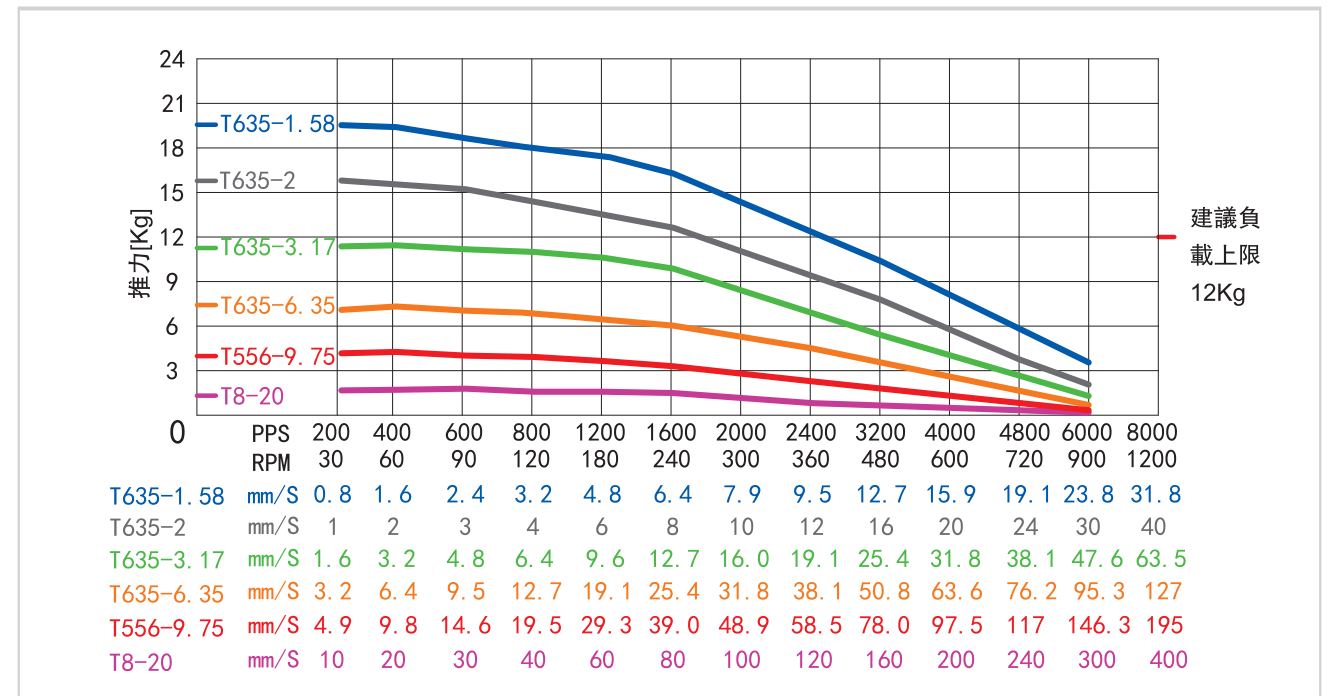

*The closed-loop version will have 10%~20% higher performance

*Use other brands of drives, safety margin must be greater than the above value 30% to 50%