

外部驱动式滚珠直线步进电机-20MBG

External Linear Actuator With Ball Screw – NEMA 8

微型集成滚珠丝杠电机，无需联轴器，电机与丝杠直接连接。节省安装空间。滚珠丝杠和螺母使用寿命更长，精度更高。提供不同长度的螺杆。还可以提供内置编码器版本。

Miniature integrated ball screw motor, without coupling, the motor and screw are directly connected. Save installation space. Ball screws and nuts provide longer life and better accuracy. Screws of different lengths available. A built-in encoder for position feedback is also available.

Feature

- Integrated structure 一体化结构
- Multiple specifications available 多种规格可选
- Longer life and higher accuracy 更长的寿命和精度
- Different lengths available 不同的螺杆长度可选
- A built-in encoder available. 内置编码器版本可选
- Motor Controllers / Drives available 电机控制器/驱动器可配套
- 0.0002mm/step with our controller 0.0002mm的最高精度 (配套我们控制器)

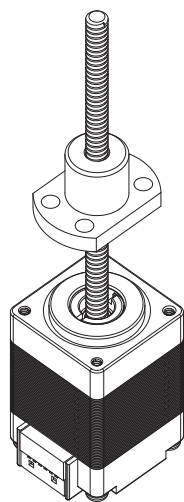

VERSIONS

系列代码 Series models	20H38MBG
相电流 Current per Winding A	0.6
静力矩 Holding Torque mN.m	25
相电阻 Resistance per Winding Ohm	9
相电感 Inductance per Winding mH	3
转子惯量 Rotor Inertia gcm ²	4
电机重量 Weight kg	0.08
电机高度 Length "L" mm	38
螺杆长度 Screw length*L1	Different lengths available
反馈装置 Feedback	Encoder(Closed-loop version)

订货代号 ORDER IDENTIFIER

20H34MBG0401E2000-L1

MBG0401=Ball Screw code
滚珠丝杠代码

L1 = Screw length
丝杠长度

E2000=Encoder resolution(Optional)
编码器分辨率 (可选)

可选螺杆 Screw optional

螺杆代码 Screw	直径 (mm) Diameter	导程 (mm) Screw lead
G0401	4	1
G0402	4	2

可选配件 ACCESSORIES

HX12500-6Y Motor Cable 0.4m
ZK-ENC-500 Encoder Cable 0.5m
Motor Controllers / Drives

外部驱动式滚珠直线步进电机-20MBG

External Linear Actuator With Ball Screw – NEMA 8

DIMENSIONS (IN MM)

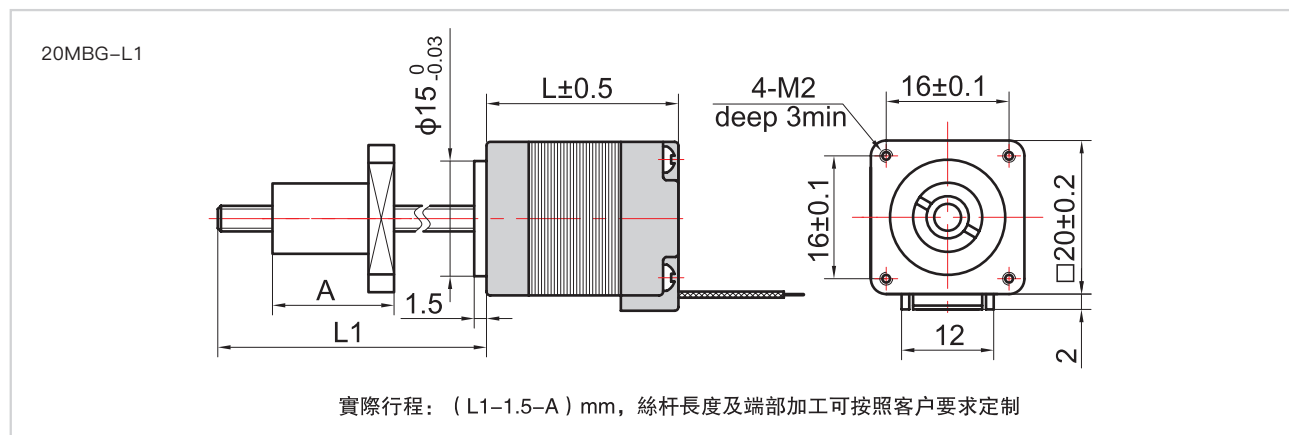

DIMENSIONS WITH ENCODER(IN MM)

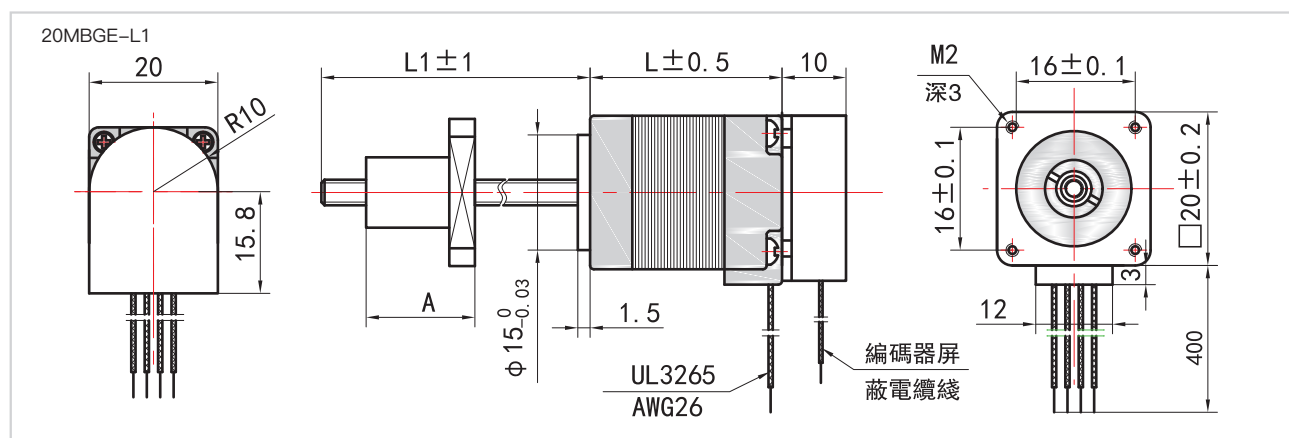

BALL SCREW DIMENSIONS (IN MM)

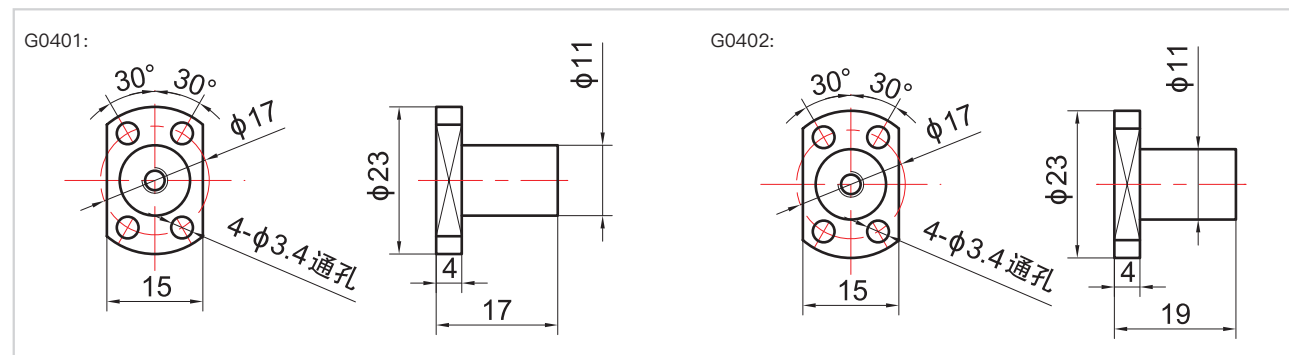

外部驱动式滚珠直线步进电机-20MBG

External Linear Actuator With Ball Screw – NEMA 8

TORQUE CURVE

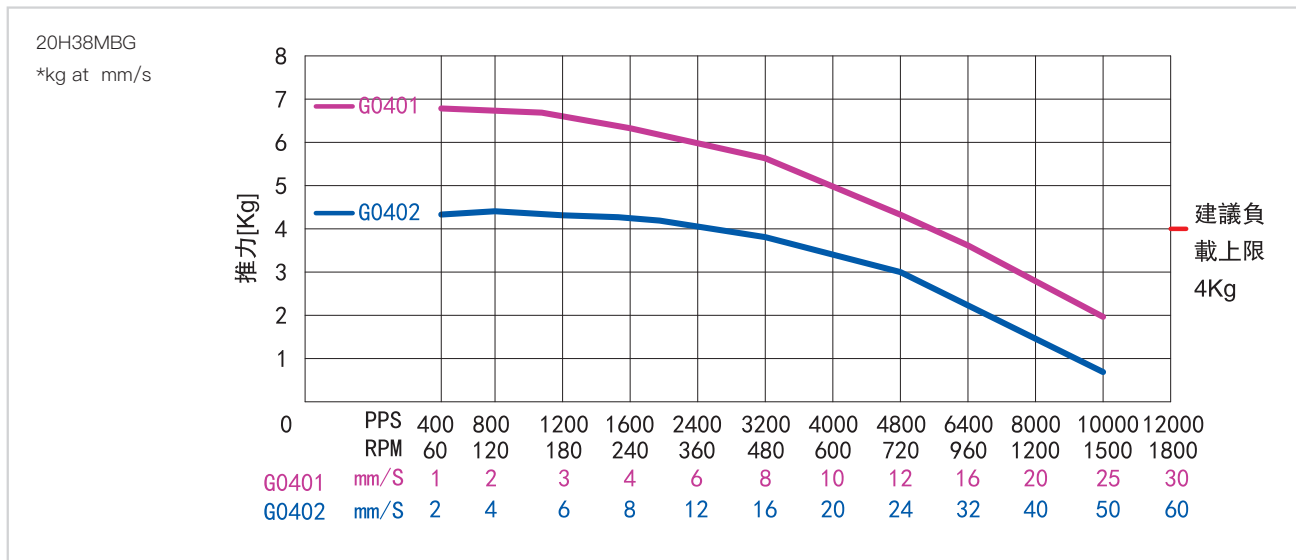

外部驱动式滚珠直线步进电机-28MBG

External Linear Actuator With Ball Screw – NEMA 11

Nema11集成滚珠丝杠电机，不带联轴器，电机与丝杠直接连接。提供两种电机高度版本。滚珠丝杠和螺母使用寿命更长，精度更高。提供不同长度的螺杆。还提供用于位置反馈的内置编码器。

Nema11 integrated ball screw motor, without coupling, the motor and screw are directly connected. Two motor height versions available. Ball screws and nuts provide longer life and better accuracy. Screws of different lengths available. A built-in encoder for position feedback is also available.

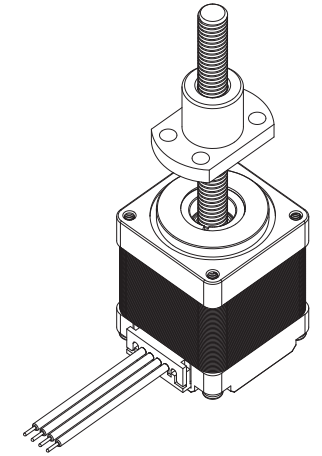

Feature

- Integrated structure 一体化结构
- Multiple specifications available 提供多种规格
- Longer life and higher accuracy 更长的寿命和更高的精度
- Different lengths available 提供不同长度
- A built-in encoder available. 提供内置编码器。
- Motor Controllers / Drives available 电机控制器/驱动器可用
- 0.0002mm/step with our controlle 使用控制器时, 0.0002mm /步

VERSIONS

系列代码 Series models	28H34MBG	28H51MBG
相电流 Current per Winding A	1.0	1.0
静力矩 Holding Torque mN.m	60	120
相电阻 Resistance per Winding Ohm	2.2	5.2
相电感 Inductance per Winding mH	1.2	4.3
转子惯量 Rotor Inertia gcm ²	9	18
电机重量 Weight kg	0.12	0.18
电机高度 Length "L" mm	34	51
螺杆长度 Screw length*L1	Different lengths available	Different lengths available
反馈装置 Feedback	Encoder(Closed-loop version)	Encoder(Closed-loop version)

订货代号 ORDER IDENTIFIER

28H34MBG0601E2000-L1
MBG0601=Ball Screw code
滚珠丝杠代码

L1 = Screw length
丝杠长度

E2000=Encoder resolution(Optional)
编码器分辨率 (可选)

可选螺杆 Screw optional

螺杆代码 Screw	直径 (mm) Diameter	导程 (mm) Screw lead
G0601	6	1
G0602	6	2
G0606	6	6

可选配件 ACCESSORIES

HX12500-6Y Motor Cable 0.4m
ZK-ENC-500 Encoder Cable 0.5m
Motor Controllers / Drives