

# 86系列中空轴步进电机-34HS

Hollow Shaft Stepper Motors – NEMA 34

## DIMENSIONS (IN MM)

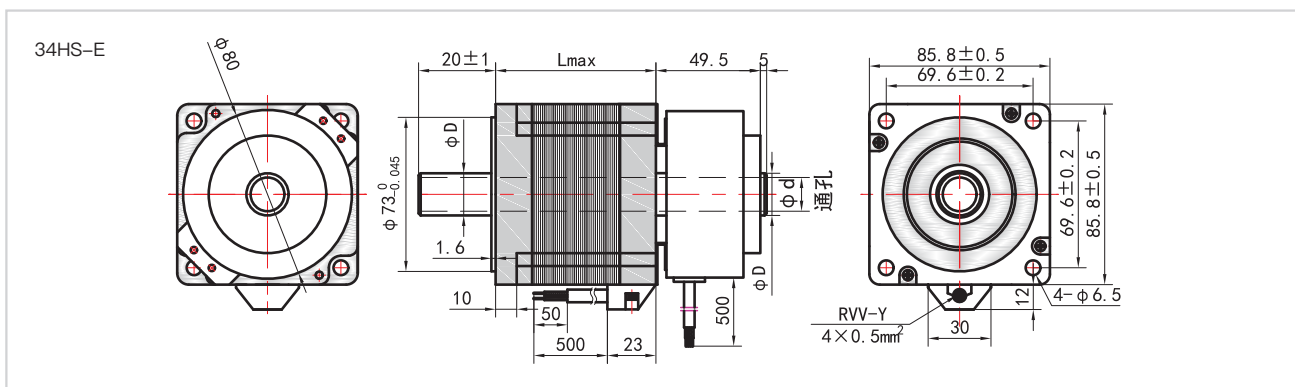

## TQRQUE (IN Nm)

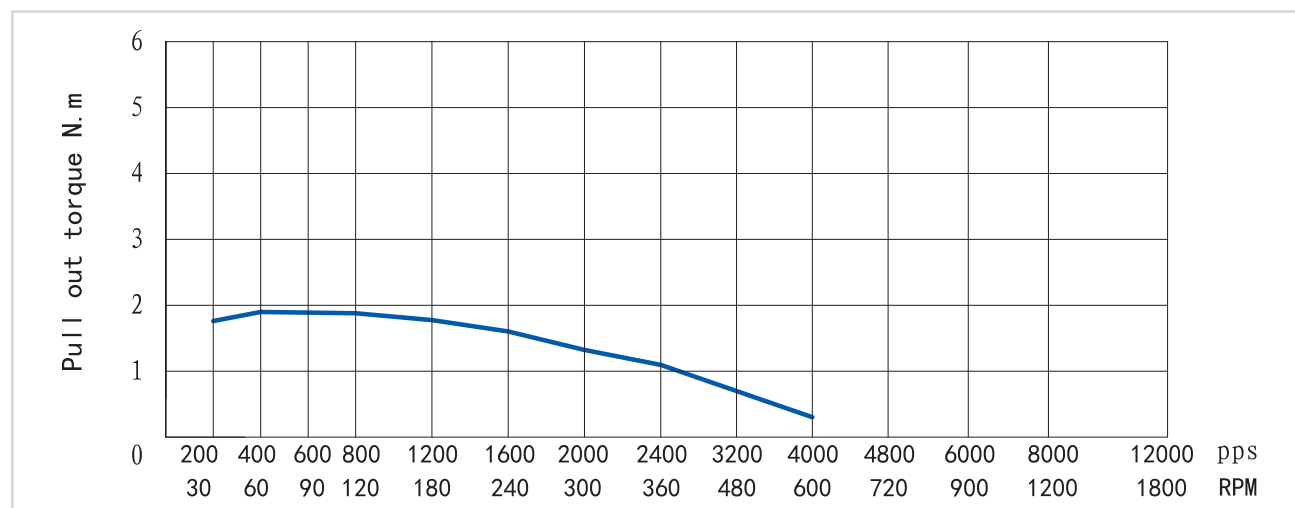

## TQRQUE (IN Nm)

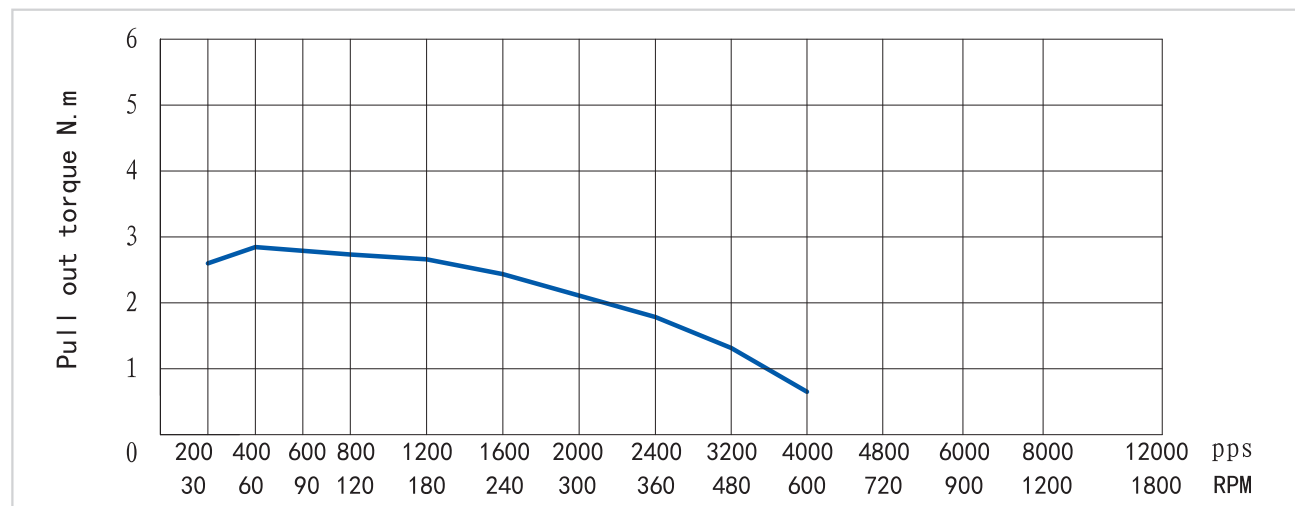

# 20系列行星减速步进电机-8HYG

Stepper With Gearbox Motors – NEMA 8

灵活的紧凑型步进电机，尺寸为 NEMA 8 (20 mm)，提供多种长度和不同的绕组，电机尾部可选装编码器。

Flexible compact stepper motor, size NEMA 8 (20 mm), provides a variety of lengths and different windings, motor optional encoder.

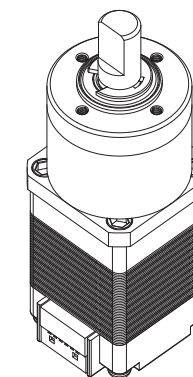

## Feature

- Micro stepping motor 微型步进电机
- 20mm small size 20系列法兰
- Encoder optional 可配套编码器
- Longer life and higher accuracy 更长的寿命和更高的精度
- Different lengths available 提供不同长度
- Motor Controllers / Drives available 电机控制器/驱动器可用

## VERSIONS

系列代码 Series models	8HS30G	8HS40G
相电流 Current per Winding A	0.6	0.6
静力矩 Holding Torque mN.m	18	32
相电阻 Resistance per Winding Ohm	6.5	6
相电感 Inductance per Winding mH	1.7	2
转子惯量 Rotor Inertia gcm <sup>2</sup>	2	3
电机重量 Weight kg	0.06	0.1
电机高度 Length "L" mm	30	40
电机法兰 Motor flange mm	20	20
反馈装置 Feedback	Encoder(Closed-loop version)	Encoder(Closed-loop version)

## 订货代号 ORDER IDENTIFIER

**8HS30G-E2000-R4**  
 8HS30=Motor body code电机代号  
 G=减速箱代码  
 E2000=Encoder 2000/Resolution  
 E2000=编码器 2000刻度  
 R=圆出轴  
 D=扁出轴

## 可选减速箱 Gearbox optional

减速比	4	4 <sup>3</sup> / <sub>4</sub>	16	19	22 <sup>9</sup> / <sub>16</sub>	64	76	90 <sup>1</sup> / <sub>4</sub>	107 <sup>11</sup> / <sub>64</sub>
减速级数	1	2	3						
L1 箱体长度	20.5mm	25.7mm	30.95mm						
最大允许转矩	0.5N.m	0.7N.m	0.9N.m						
回程间隙	≤3°	≤3°	≤3°						
传动效率	90%	80%	70%						

## DIMENSIONS (IN MM)

